

PGT-11-S



Technical Information

BU	BU71
Type	PC Programming Unit
Input Power	12V
Windows compatible	WIN7 / WIN10 compatible
Software	SOPAS
Release Date	08.2014
Phase out	WLAN version July 2020 07/2020 - Phase out of PGT-11-S WLAN version

Links

[PGT-11-S SICK.com](#)

[PGT-11-S PI de](#)

[PGT-11-S PI en](#)

[User manual de](#)

[User manual en](#)

[Montageanleitung de en](#)

[07/2020 - Phase out of PGT-11-S WLAN version](#)

[06/2024 - PGT-11-S LAN](#)

Documents

[print of the page](#)

[available videos](#)

	<p>The Hiperface DSL Host Mode (Master Mode) https://video.sick.com/media/t/0_424kl7w5</p> <p>The encoder's user data (Hiperface DSL) Create and delete data fields https://video.sick.com/media/t/0_cjln3dwz</p> <p>Copy data fields https://video.sick.com/media/t/0_vcraofq3</p> <p>The Hiperface Host Mode https://video.sick.com/media/t/0_1gds5py5</p> <p>The encoder's user data (Hiperface) https://video.sick.com/media/t/0_4irpchen</p> <p>The Hiperface Analyzer Mode https://video.sick.com/media/t/0_0ppka2p7</p>
--	---

How to use the PGT-11-S

Table of content

- [Technical Information](#)
- [Links](#)
- [Documents](#)
- [How to use the PGT-11-S](#)
 - [Table of content](#)
 - [The Ethernet Connection](#)
 - [Basics](#)
 - [Device Identification](#)
 - [Ethernet](#)
 - [How to connect the PGT-11-S to a PC?](#)
 - [Via a Network](#)
 - [Via a direct connection](#)
 - [The Hiperface DSL Host Mode \(Master Mode\)](#)
 - [How to start the Hiperface DSL Host Mode \(Master Mode\)?](#)
 - [DSL Connection](#)
 - [Data Sheet](#)
 - [Sensor Values](#)
 - [Error Handling](#)
 - [Administration](#)
 - [Diagnostics](#)
 - [User Data](#)
 - [Create and Delete data fields](#)
 - [Copy data fields](#)
 - [Basics](#)
 - [Create Data Field](#)
 - [Read Data Field](#)
 - [Change Data Field](#)
 - [Delete Data Field](#)
 - [Resources](#)
 - [Advanced](#)
 - [Direct Input](#)
 - [Registers](#)
 - [Memo Dump](#)
 - [The Hiperface DSL Emulator Mode \(Slave Mode\)](#)
 - [What is the sense of it?](#)
 - [The Hiperface DSL Analyzer Mode](#)
 - [What is the sense of it?](#)
 - [The Hiperface Host Mode \(Master Mode\)](#)
 - [How to start the Hiperface Master Mode?](#)
 - [Datasheet](#)
 - [Programming](#)
 - [Data Field Management](#)
 - [Create Datafield](#)

- Read Datafield
 - Change Datafield
 - Delete Datafield
- Position
 - Administration
 - Diagnosis
- The Hiperface Analyzer Mode
 - How to start the Hiperface Analyzer Mode?
 - What is the sense of it?
 - The Oscilloscope Mode
 - The Hiperface Tap
- Incremental Encoders (only VFS60)
- Incremental with Commutation (only the CKS36-PFBPROGR)
- FAQ
 - Problems with the Set Position at a EKS36 / EKM36, in combination with the PGT-11-S, with STM32 controller
 - Basic Problem
 - What is the Problem with the PGT-11-S?
 - How to solve the problem?
 - How to enable the Access Level at a EKx36 with STM32 via the API
 - !!! internal !!! only for customers which are using the PGT-11-S via the API

The Ethernet Connection

Basics

The PGT-11-S is connected via a network connection to the PC. There are 2 options to do this:

- Via a Network
- Via a direct connection

For the communication, it is necessary to install [SOPAS](#) on your PC. There is also the right PGT-11-S SDD file needed (sopas device description).

Device Identification

There you find some basic Identification information about the PGT-11-S

- Not changeable attributes: Name, Serial number
- Attributes which the PGT-11-S can change: Version, Firmware version depends on the installed firmware
- Attributes, which the customer can change: Location name can be changed in the Authorized Client mode (password: AuthdClient)

Ethernet

Here you see the current network settings.

There is also the possibility to change the network mode:

- DHCP
- Auto IP
- Manual IP

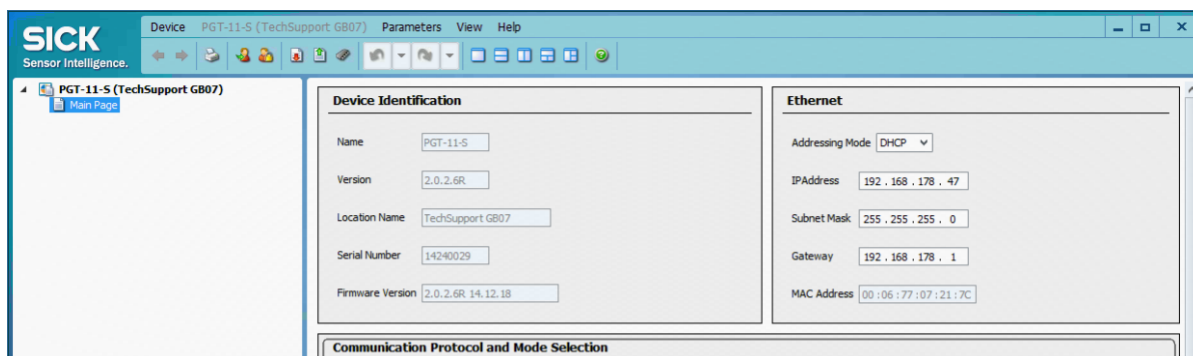

How to connect the PGT-11-S to a PC?

There are basically 2 ways, how to connect the PGT-11-S to the PC.

Via a Network

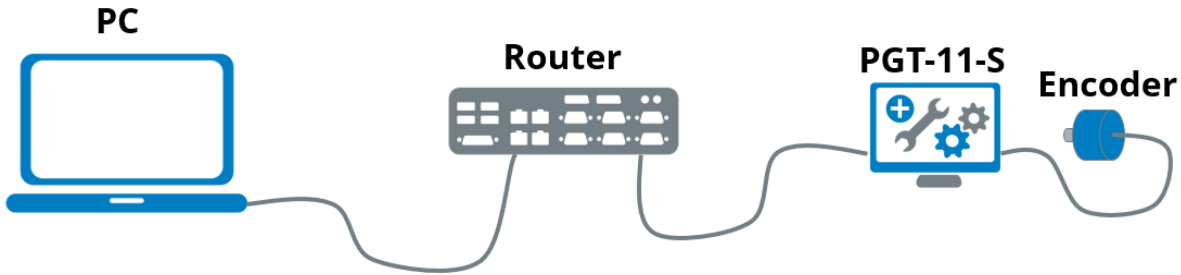

This kind of connection requires a "router" (a standard switch is for the full functionality not sufficient). The router includes a DHCP-Server.

If you want to use this way of connection, it is important, that the PGT-11-S has the network setting "DHCP".

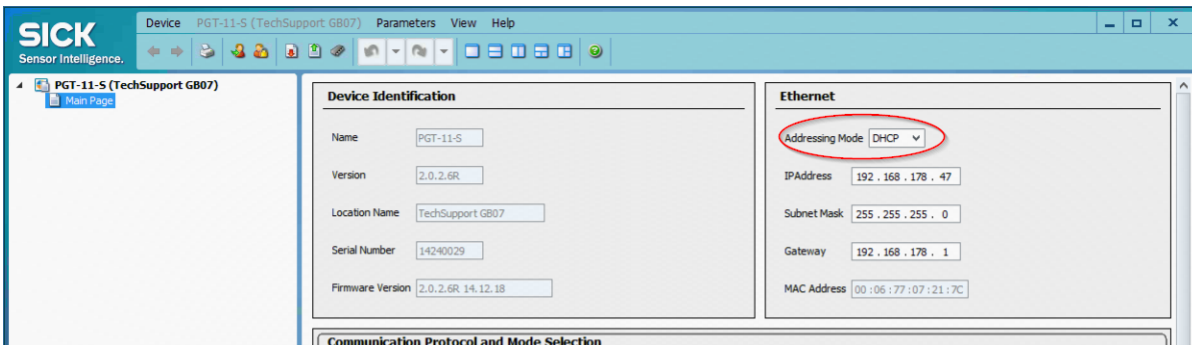

Please keep in mind! If you have adjusted the Addressing Mode "DHCP", then you need definitely a DHCP server in your network.

Without DHCP server, the PGT-11-S doesn't get a IP-address without IP-address, no communication.
Without communication, no possibility to switch back to another network setting.

Via a direct connection

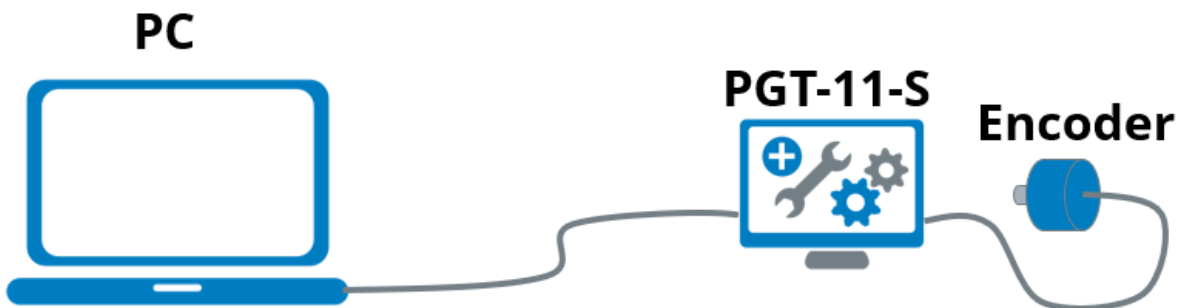

It is possible to make a direct connection between the PC and the PGT-11-S. To get this work, you need the right adjustments in the IP-address settings of the PGT-11-S and the PC.

PGT-11-S:

- Auto IP (default setting when shipped to the customer)
At this setting, the PGT-11-S checks the IP-addresses of the other devices in the network. Then, the PGT-11-S gives itself an IP-address, which fits to the other devices in the network.
- Manual IP
It is possible to adjust the IP-addressing manual. If this is done, the customer has to be sure, that the used PC has an IP-address (and Subnet Mask) which fits to the PGT-11-S.

PC:

- DHCP/Auto IP
If the PC is adjusted to DHCP, then it is waiting to get an IP-address. If it gets no IP-address, it switches to an auto IP mode. Then it gives itself an IP-address which fits to the other devices.
If the PC and the PGT-11-S are set to Auto IP, then it takes approx. 1 minute until a communication is possible (so please be patient 😊)
- Manual IP
The PC has a fix IP-address
If the PGT-11-S is adjusted to Auto IP, then it gives itself a fitting IP address.
If the PGT-11-S is also adjusted to a manual IP-address, then the IP-addresses have to be in the same range (if not, a communication will be not possible)

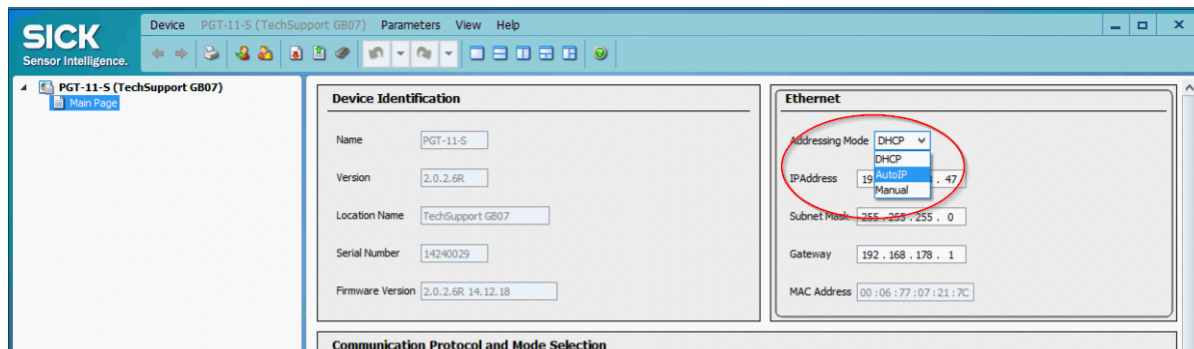

The Hiperface DSL Host Mode (Master Mode)

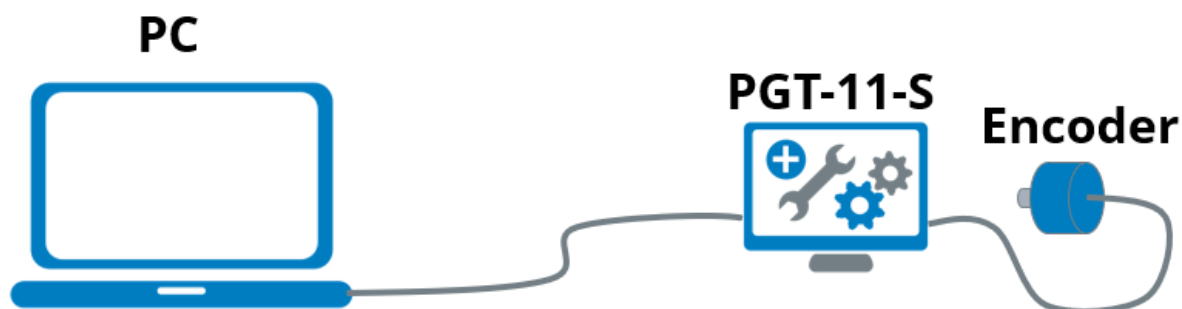

https://video.sick.com/media/t/0_424kl7w5

How to start the Hiperface DSL Host Mode (Master Mode)?

1. Choose the Interface Hiperface DSL
2. Select the Hiperface DSL Master Mode

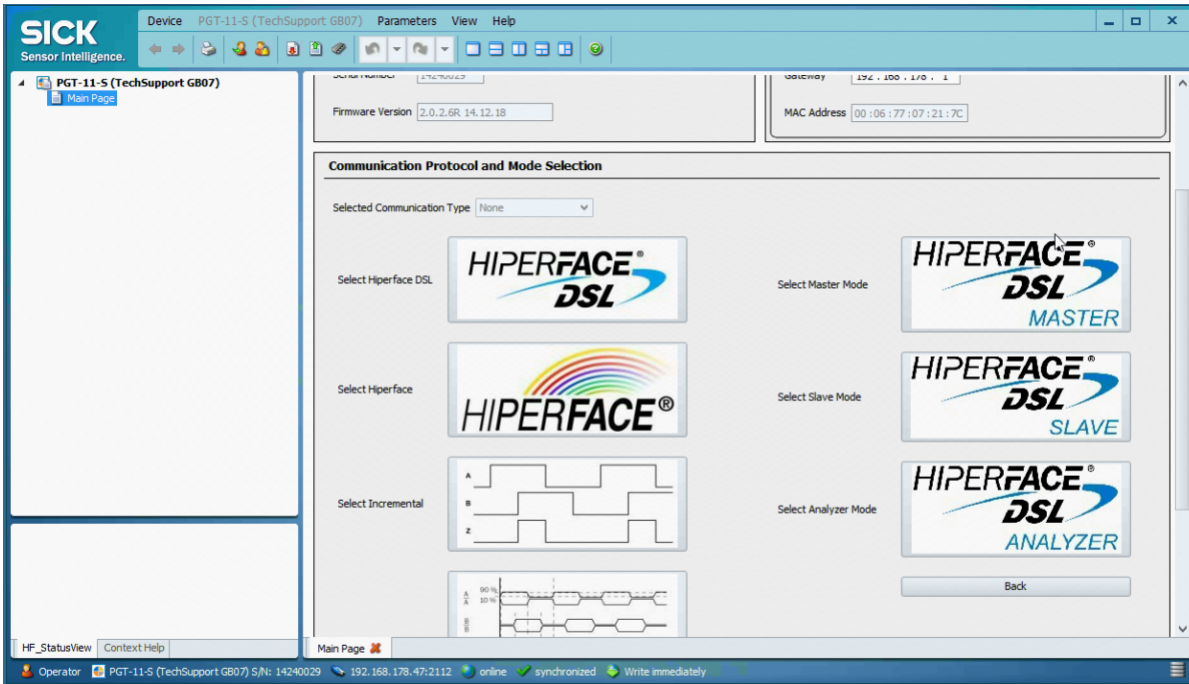

DSL Connection

The tab "DSL Connection" shows information about the Hiperface DSL connection quality between the encoder and the PGT-11-S.

- Line Delay / Line Jitter:
 - Source: IP-Core Register "0Ah", Bit 0..3 (Cable Delay)
 - This resource gives Feedback about the cable length between the encoder and the PGT-11-S. It is the time, between the Master's Request and the Slave's Respond in "ns"
- Line Signal Strength:
 - Source: IP-Core Register "0Ah", Bit 4..7 (RSSI)
 - This value gives feedback, how precise are the edges of the digital signal.
- Quality Monitor
 - Source: IP-Core Register "03h", Bit 0..3 (Quality monitoring)
 - This is an event based quality feedback of the Hiperface DSL connection
- IP-Core PGT-11-S Major Version / IP-Core PGT-11-S Minor Version
 - The IP-Core version of the PGT's IP-Core (this has nothing to do with the encoder)
- Encoder ID
 - Source: IP-Core Register "0Dh .. 0Fh"

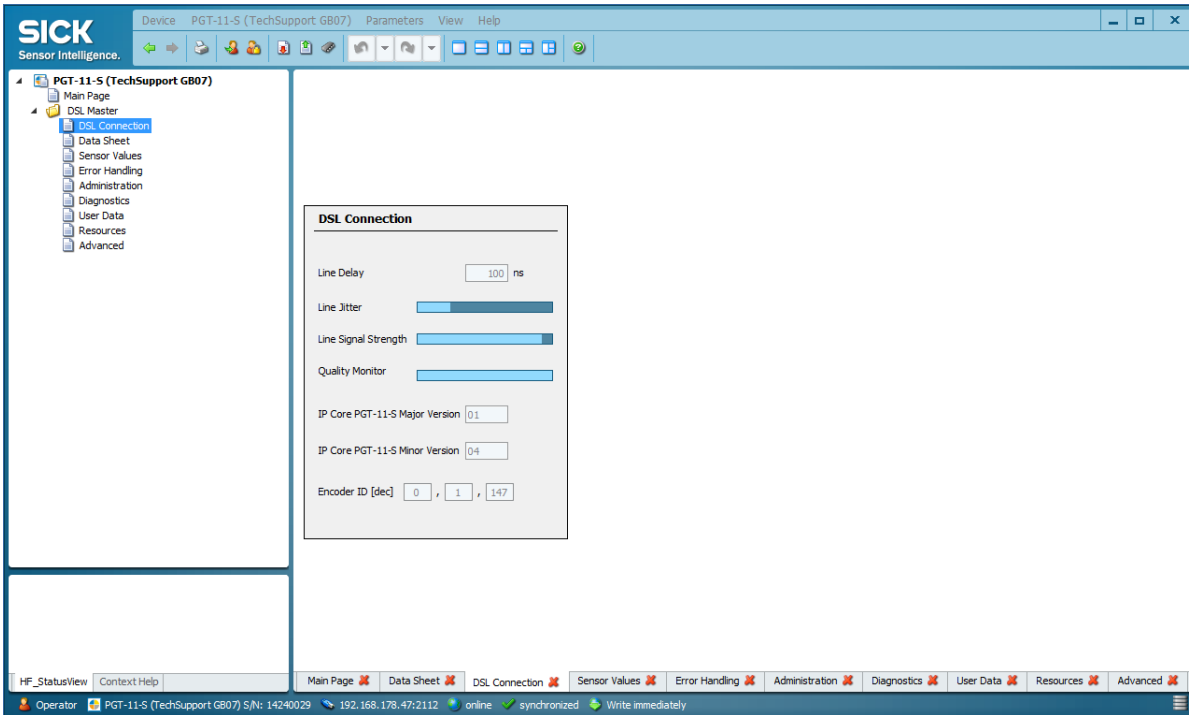

Data Sheet

The tab "Data Sheet" displays values, which are directly read out from the encoder via long messages

- Encoder Type Resource 83h
- Firmware Revision Resource 85h
- Firmware Date Resource 86h
- Hardware Revision Resource 85h
- Serial No. Resource 84h
- User Memory (Byte) Resource 87h
- Free Memory (Byte) Resource 134h
- Number of Data Fields Resource 134h
- Max Speed (rpm) Resource C6h
- Min. Supply Voltage (V) Resource C4h
- Max. Supply Voltage (V) Resource C4h
- Min. LED Current (mA) Resource C2h
- Max. LED Current (mA) Resource C2h
- Min. internal Temperature (°C) Resource C0h
- Max. internal Temperature (°C) Resource C0h
- Resolution per Revolution Resource 81h
- Number of Turns Resource 82h
- Max. Acceleration (1000 rad/s²) Resource C8h

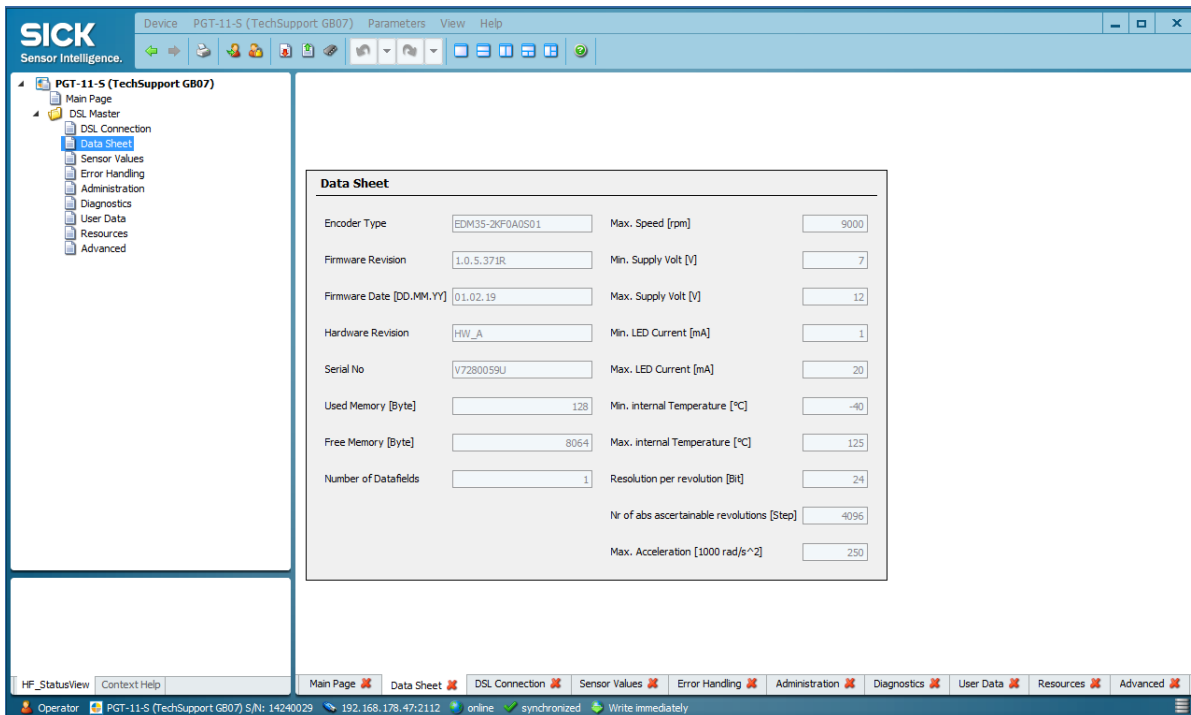

Sensor Values

The tab "Sensor Values" responds the most important cyclic and acyclic measuring values.

- Cyclic Measuring values directly readable from the IP-Core registers.
 - Fast Position Register 10h .. 14h (Drive Interface)
 - Speed Register 15h .. 17h (Drive Interface)
 - Safe Position 1 Register 19h .. 1D (Safe Interface 1)
 - Safe Position 2 Register 19h .. 1Dh (Safe Interface 2) This value is transmitted inverted
- Acyclic Measuring values readable via a "Long message" (to read out those values, it is important to mark the checkbox "Update Continuously" otherwise, the values are only filled at the start up)
 - Encoder Temperature Resource C1h
 - LED Current Resource C3h
 - Supply Voltage Resource C5h
 - Speed Resource C7h
 - Input 1 (Resistor input for the external temperature sensor) Resource 200h
- Set Position
With the "Set Position" it is possible to set the encoders position value to a predefined value. This function executes the Resource 101h.
- Value Logging
With the function "Value Logging" it is possible to put a measuring value into a graph.
 - Select the source
 - make a tick into the checkbox collect than the last 200 values are shown
 - With "clear" you can delete the graph

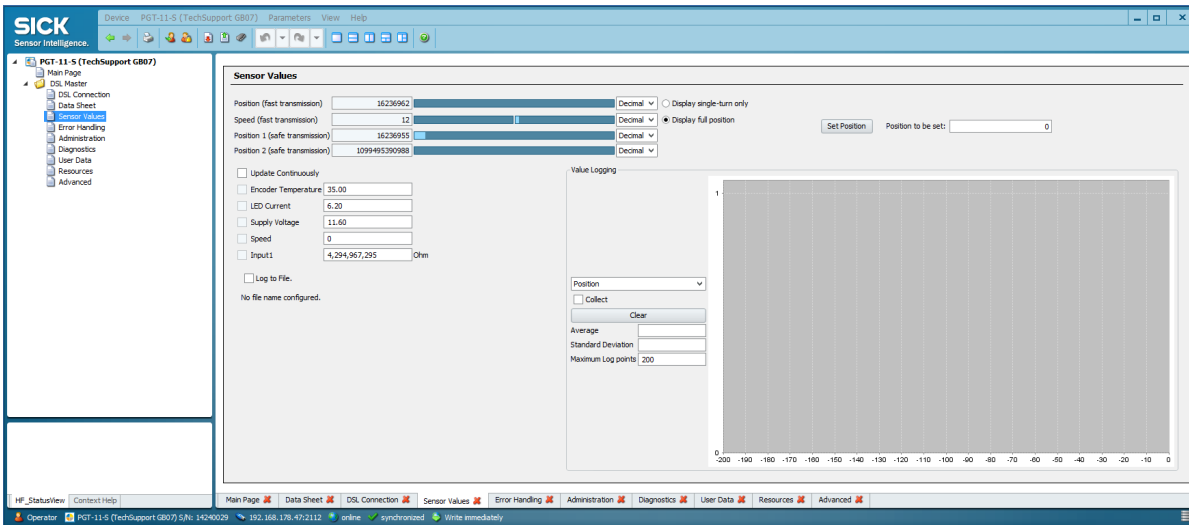

Error Handling

The area "Error Handling" is split in 2 parts

1. On the left side, we see flags from the IP-Core
don't care much about those flags, because they are generated by the PGT-11-S itself. Those flags are usually needed, to control the encoder.
2. On the right side, we see error and warning flags from the Encoder.
Those error messages are directly read out from the encoder via a "Short Message"

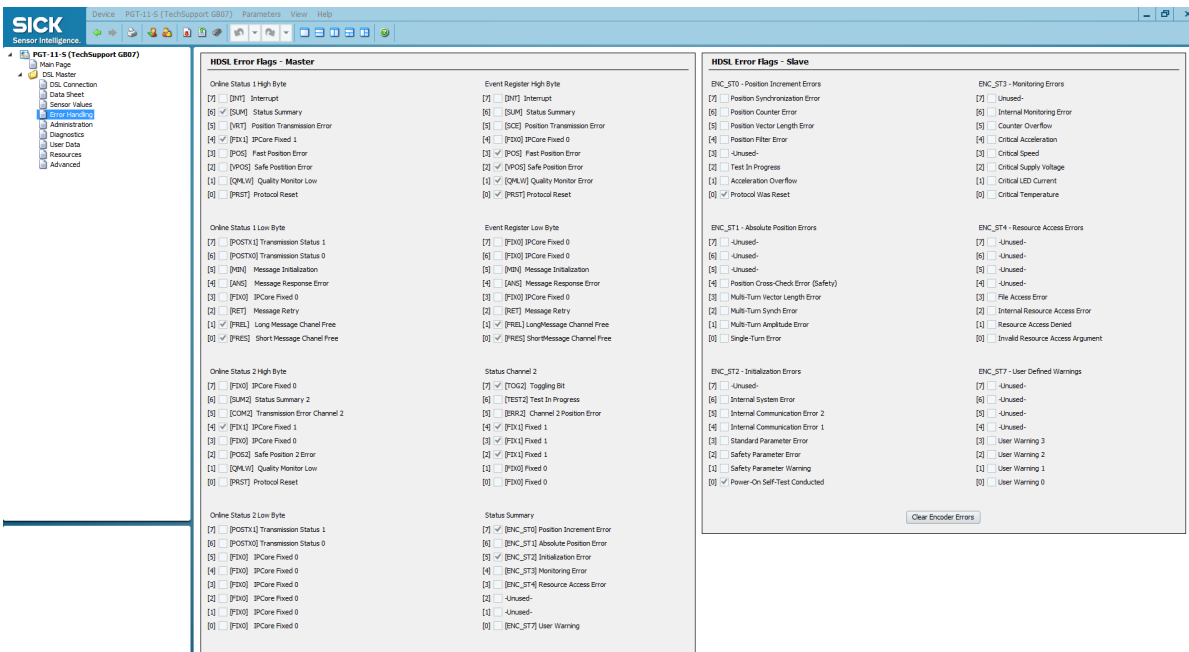

Administration

The "Administration" tab includes 2 functionalities: 1. Encoder, 2. User Boundaries

- **Encoder**
 - Encoder Reset performs a soft reset at the encoder (the encoder is restarting itself) Resource 100h
 - Set Encoder Index Adjust the encoder index Resource 109h/111h (needed for SAFEDSL022)
 - Set Position Filter to reduce the signal noise of the encoder (but the encoder's position value becomes more slow) usually the factory settings are used
 - Encoder Factory Reset to perform a Factory Reset at the encoder (set to default) Resource 108h
For the Factory Reset, there is a code needed (see table below), to perform the reset.

--	--	--

	Code	Functionality
1	RESETUFS	Reset of the File System
2	RESETALL	Reset of the File System Reset of the Error Log

- **User Boundaries**

Here it is possible to adjust user specific error messages which are based on the existing resources. The generated error messages are than visible in the error Byte 7 (see Error Handling, encoder side).

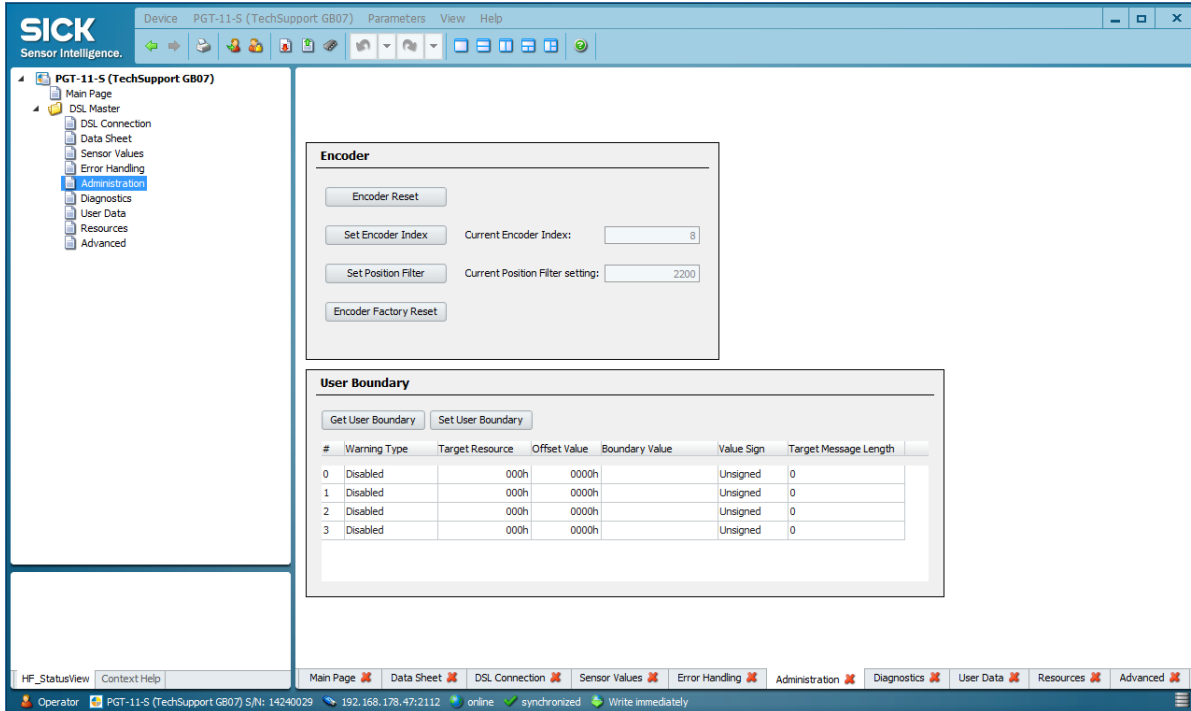

Diagnostics

Here we can see the Lifetime of the encoder. The area is separated in the "Error Log" and the "Histogram"

- **Error Log**

Shows the last 16 Errors, which the encoder has generated.

To each error, there are the current encoder conditions tracked, which are:

- Error time (Lifetime of the encoder in min)
- Encoder Temperature
- LED Current / Rotor Position
- Supply Voltage
- Speed

- **Histogram**

The Histogram gives a little bit an overview, how the encoder was used. The Histogram works like this: Each minute, the encoder captures a value from 4 defined resources and counts it in a table. After 20 minutes, the values are written into the EEPROM.

The values, which are counted are:

- Encoder Temperature
- LED Current / Rotor Position
- Supply Voltage
- Speed

- **Diagnostic Report**

It is possible to generate a "Diagnostic Report" with all the relevant data, which is possible to Read out with the PGT-11-S

The content of the Diagnostic Report is:

- Information about the PGT-11-S
- Information about the connected encoder
- The current error conditions
- The Error Log
- The Histogram data

The screenshot displays the SICK Sensor Intelligence software interface. The main window is titled "PGT-11-S (TechSupport GB07)". The interface is divided into several sections:

- Left Panel:** A tree view showing the software's structure, including "Main Page", "DSL Master", "DSL Connection", "Data Sheet", "Sensor Values", "Error Handling", "Administration", "Diagnostics" (selected), "User Data", "Resources", and "Advanced".
- Error-Log:** A table displaying error records. The columns are Index, Error Code [hex], Description, Error Time [min], Temperature [°C], LED Current [mA], Supply Voltage [V], and Speed [rpm]. The table contains 10 rows of data, all with a description of "Resource access denied." or "Invalid resource access argument.".
- Histogram:** A section for data visualization. It includes radio buttons for "None", "Encoder Temperature", "LED current", "Supply Voltage", and "Speed". A table with "Category" and "Amount" columns is present but empty. To the right, there are input fields for "Operation Time [min]" (value: 98609) and "Total Shaft Turns" (value: 6).
- Diagnostic Report:** A section with a "Create" button.
- Bottom Panel:** A status bar showing various system indicators and a taskbar with open windows like "Main Page", "Data Sheet", "DSL Connection", "Sensor Values", "Error Handling", "Administration", "Diagnostics", "User Data", "Resources", and "Advanced".

User Data

Create and Delete data fields

https://video.sick.com/media/t/0_cjln3dwz

Copy data fields

https://video.sick.com/media/t/0_vcroafq3

In the Tab "User Data" it is possible to create, read, change and delete user specific data fields.

SICK only provides the functionality of the data fields. But SICK has nothing to do with the content of the data fields. The content is defined by the drive manufacturer or motor manufacturer.

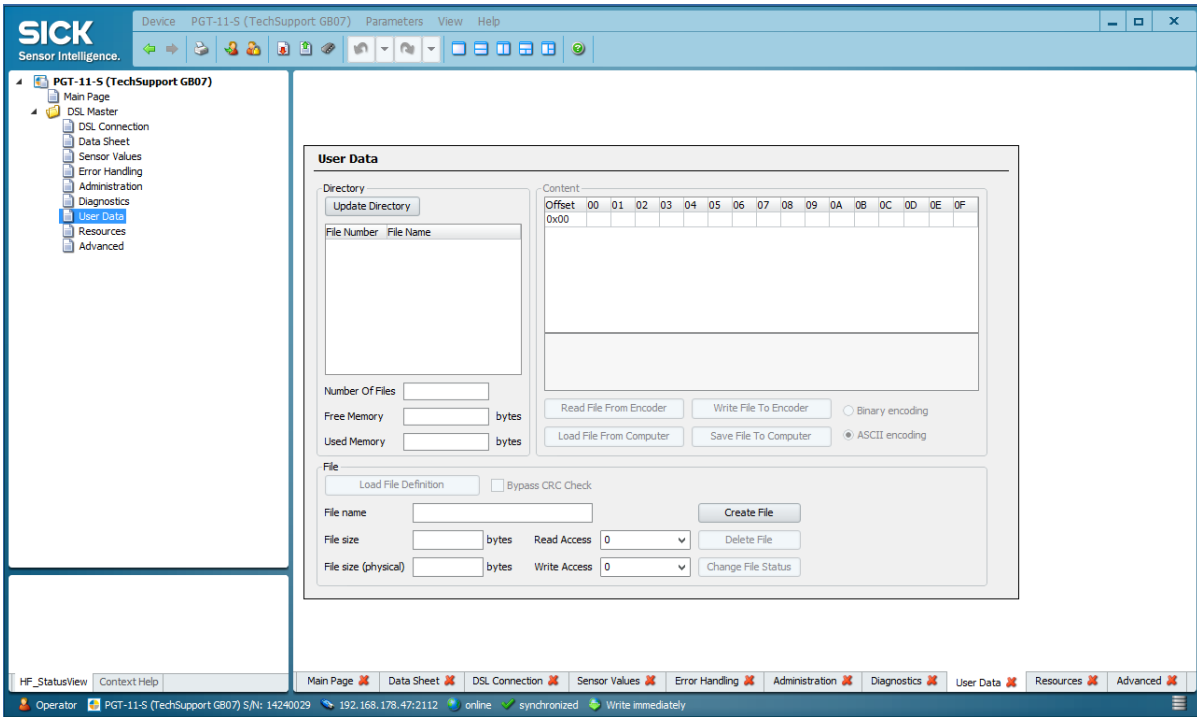

Basics

At 1st, before you can create, read, change, or delete files, you have to check, if there are files on the encoder.

For this, please choose "Update Directory". In the background, the PGT-11-S is reading the resource "DIR, 134h".

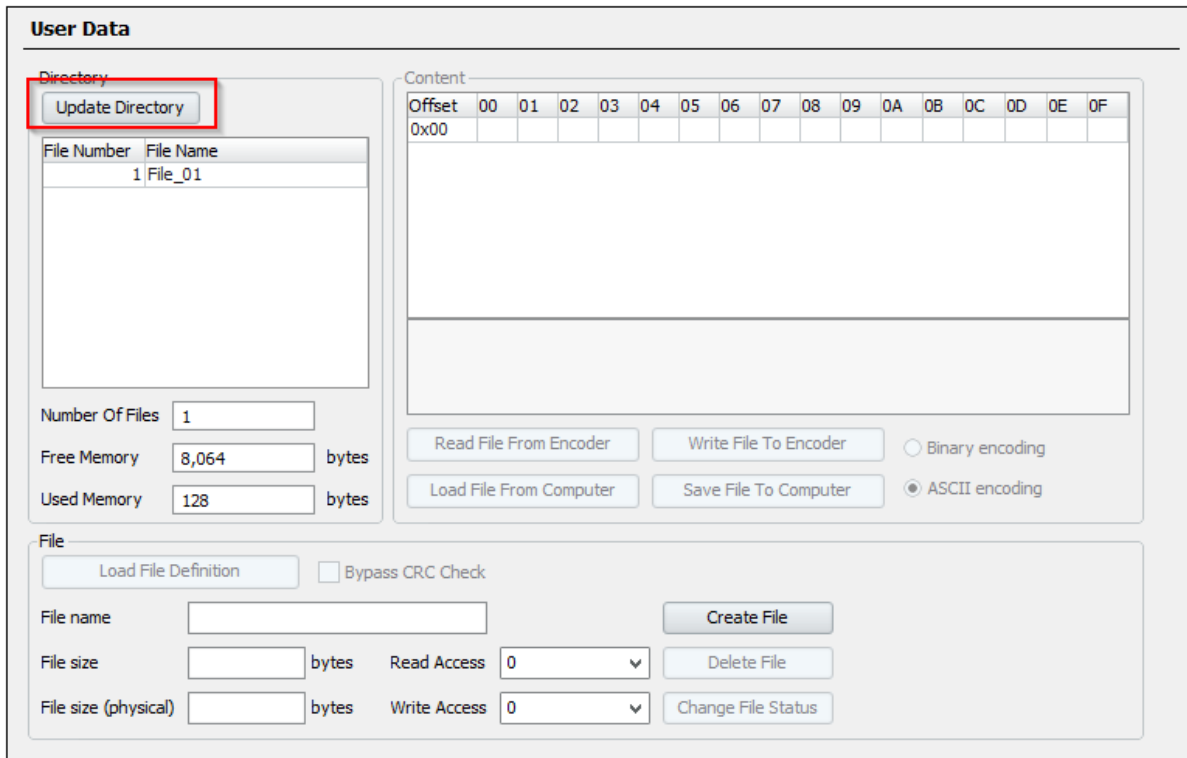

Each other functionality is a combination of reading and writing "data storage resources". The PGT-11-S is doing this automatically, if you work with the GUI.

Functionality	How to do	used Resources

check the existing data fields	Directory	DIR, 134h
create and write to a new file	Create file Write file	MAKEFILE, 133h RWFIL, 131h
read the status of a file	Load file File status	LOADFILE, 130h FILESTAT, 132h
read from a file	Load file Read file	LOADFILE, 130h RWFIL, 131h
write to an existing file	Load file Write file	LOADFILE, 130h RWFIL, 131h
change the status of an existing file	Load file Change file	LOADFILE, 130h MAKEFILE, 133h
delete file	Load file Delete file	LOADFILE, 130h MAKEFILE, 133h

Create Data Field

The functionality is split into 2 steps.

1. Create the file (without the content)

Create a file name (maximum 8 digits long) and confirm with "Create file".

If necessary, you can also define access levels (read access / write access) for the data field.

User Data

Directory

Update Directory

File Number	File Name
1	File_01

Number Of Files: 1

Free Memory: 8,064 bytes

Used Memory: 128 bytes

Content

Offset	00	01	02	03	04	05	06	07	08	09	0A	0B	0C	0D	0E	0F
0x00																

Read File From Encoder Write File To Encoder Binary encoding

Load File From Computer Save File To Computer ASCII encoding

File

Load File Definition Bypass CRC Check

File name: **Create File**

File size: bytes Read Access: 0 Delete File

File size (physical): bytes Write Access: 0 Change File Status

2. Choose the file (1) and "Load" (2) the file.

Then you can edit (3) the content and "Write File To Encoder" (4)

(It is possible to edit the content of the file in "ASCII" (default) or in "HEX" you can choose this in the checkboxes below the edit area.

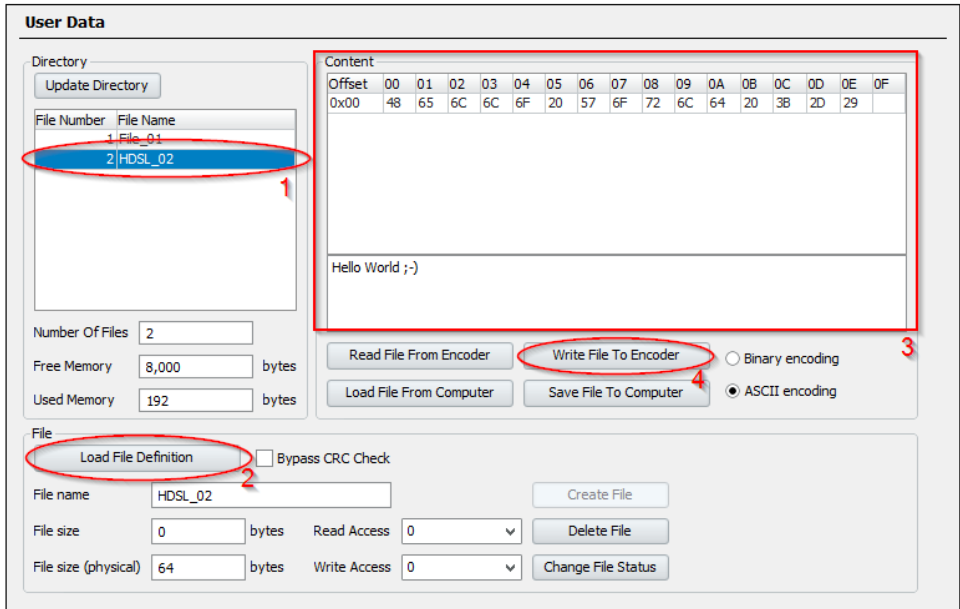

It is also possible to load some content from the PC, with "Load File from Computer"

Read Data Field

After "Update Directory", you can Choose the file (1) you want to read and "Load File Definition" (2). Then you can "Read File from Encoder" (3). Then you see the content of the file.

If you want, you have the possibility to save the content of the data field on the PC (4) Important! Only the content of the file is stored, **not the status** information of the file, as name, read access, write access.

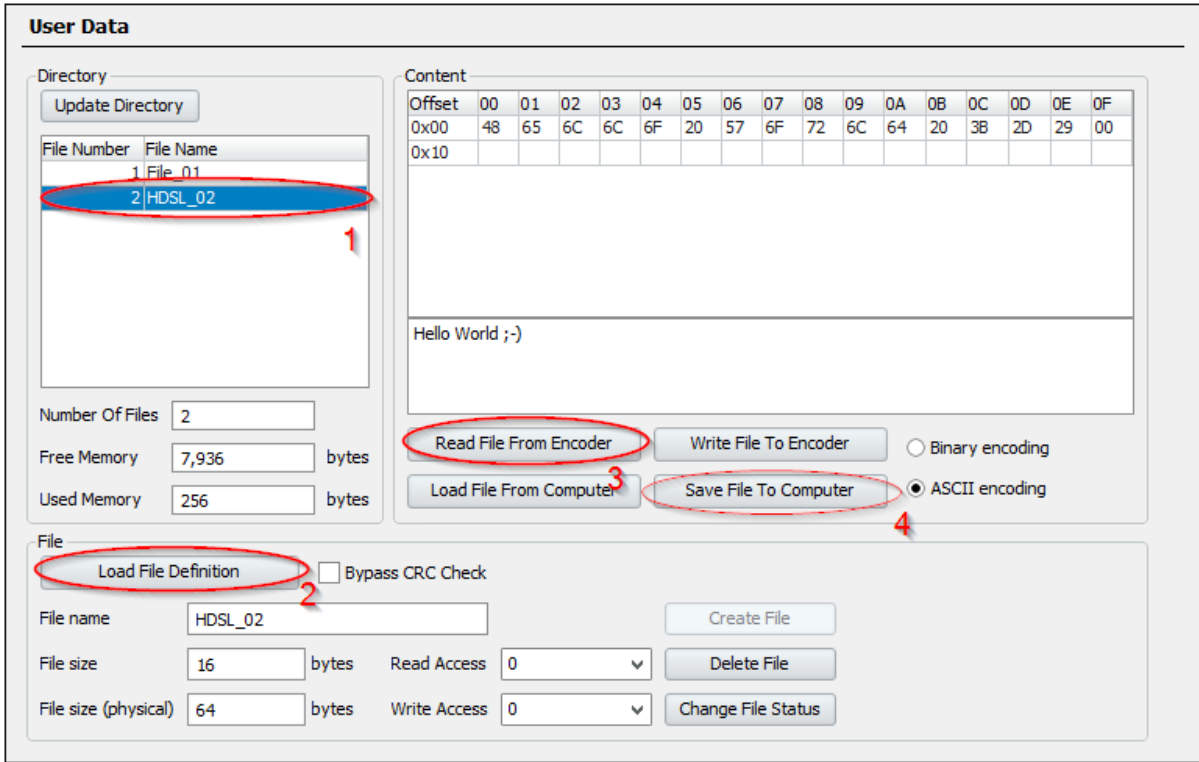

Change Data Field

There are 2 parts, which are possible to edit. 1. Content of the data field, 2. Status of the data field.

For both functions, it is at 1st necessary to "Read the Data Field" as described above.

1. Change Content of the data field

Edit the content in the text field (ACII or HEX) and press "Write File To Encoder"

User Data

Directory

Update Directory

File Number	File Name
1	File_01
2	HDSL_02

Number Of Files: 2

Free Memory: 7,936 bytes

Used Memory: 256 bytes

Content

Offset	00	01	02	03	04	05	06	07	08	09	0A	0B	0C	0D	0E	0F
0x00	48	65	6C	6C	6F	20	57	6F	72	6C	64	20	3B	2D	29	20
0x10	0A	69	74	27	73	20	6D	65	21	21						

Hello World ;-)
it's me!!

Read File From Encoder **Write File To Encoder** Binary encoding

Load File From Computer Save File To Computer ASCII encoding

File

Load File Definition Bypass CRC Check

File name: HDSL_02 Create File

File size: 16 bytes Read Access: 0 Delete File

File size (physical): 64 bytes Write Access: 0 Change File Status

2. Change Status of the data field

Edit the Status information (file name, read access, write access) of the data field and confirm it with "Change File Status".

User Data

Directory

Update Directory

File Number	File Name
1	File_01
2	HDSL_02

Number Of Files: 2

Free Memory: 7,936 bytes

Used Memory: 256 bytes

Content

Offset	00	01	02	03	04	05	06	07	08	09	0A	0B	0C	0D	0E	0F
0x00	48	65	6C	6C	6F	20	57	6F	72	6C	64	20	3B	2D	29	20
0x10	0A	69	74	27	73	20	6D	65	21	21	00	00	00	00	00	00
0x20	0A	00	00	00	00	00	00	00								

Hello World ;-)
it's me!!

Read File From Encoder Write File To Encoder Binary encoding

Load File From Computer Save File To Computer ASCII encoding

File

Load File Definition Bypass CRC Check

File name: HDSL_02x Create File

File size: 40 bytes Read Access: 1 Delete File

File size (physical): 64 bytes Write Access: 1 **Change File Status**

Delete Data Field

Choose the data field you want to delete (1), then click "Load File Definition" (2). Then press "Delete File" (3).

User Data

Directory

Update Directory

File Number	File Name
1	File_01
2	HDSL_02x

Number Of Files:

Free Memory: bytes

Used Memory: bytes

Content

Offset	00	01	02	03	04	05	06	07	08	09	0A	0B	0C	0D	0E	0F
0x00																

Binary encoding

ASCII encoding

File

Bypass CRC Check

File name:

File size: bytes Read Access:

File size (physical): bytes Write Access:

Resources

In the Tab "Resources" it is possible to read out the encoder specific resource list. Then it is possible to see, which resources the encoder is supporting and how they are working.

Resources are needed for the acyclic communication, which is handled by "Long Messages".

The screenshot shows the SICK Sensor Intelligence software interface. The main window displays the "Resource Database" configuration page. On the left, a tree view shows the navigation menu with "Resources" selected. The main area contains a "NOT LOADED" message and an "Update Resource Database" form with the following fields:

- Resource Id:
- Resource Name:
- Resource Size:
- Read Access:
- Write Access:
- Timeout: ms
- Value Sign:

The bottom status bar shows the device information: PGT-11-S (TechSupport GB07) S/N: 14240029, IP: 192.168.178.47:2112, and status indicators for online, synchronized, and write immediately.

Advanced

In the tab "Advanced" you have the possibility to simulate a direct communication with the Encoder or the IP-Core. There are basically 3 functionalities:

1. Direct Input (Long Message communication)
2. Registers (direct read out of Master IP-Core registers)
3. Memo Dump (Load an encoder back up for SICK internal use)

The screenshot shows the SICK Sensor Intelligence software interface for device PGT-11-S (TechSupport GB07). The interface is divided into several sections:

- Direct Input:** A table with columns: RID, Indirect, UseOffset, Offset (in Hex), Length, Read, Write, Request (in Hex), and Response (in Hex). Below the table are buttons for "Send Once", "Start Polling", "Stop Polling", "Save Macro", "Load Macro", "Clear Macro", "Set Command Line", and "Delete Command". There is also a "Log to File" checkbox and the text "No file name configured."
- Registers:** This section contains three groups of controls:
 - DSL Master Register Channel 1:** A dropdown menu showing "0x00 - SYS_CTRL", with "Set Master Register" and "Read Master Register" buttons.
 - DSL Remote Register:** A dropdown menu showing "0x20 - PC_BUFFER0", with "Set Remote Register" and "Read Remote Register" buttons.
 - DSL Master Register Channel 2:** A dropdown menu showing "0x0F - ENC2_ID", with "Set Master Register" and "Read Master Register" buttons.
- Memory-Dump:** A section with a "Log to File" checkbox and the text "No file name configured."

The bottom status bar shows the user is "Operator" and the device is "online" and "synchronized".

Direct Input

In the example, there is a read out of the Encoder's internal temperature:

Open a new command line with "Set Command Line", put in the data and execute with "Send Once".

Here an example:

1. RID = Resource which should be used in the example: **Encoder temperature C1h**
2. Indirect = disable: reads the attributes of the resource; **enable**: uses the resource
3. Use Offset = needed, if the data is longer than 8 Bytes
4. Offset = only if used (in the example not)
5. Length = 2, 4, or 8 Bytes (in the example 2 Bytes)
6. Read or Write = how the resource is used (in the example Read)
7. Request / Response = data of the resource (in the example 01 AB h / The temperature value is transmit in 0.1°C steps 01ABh = 427dec 42.7°C)

Direct Input

RID	Indirect	UseOffset	Offset (in Hex)	Length	Read	Write	Request (in Hex)	Response (in Hex)
c1	<input checked="" type="checkbox"/>	<input type="checkbox"/>		2	<input checked="" type="checkbox"/>	<input type="checkbox"/>		01 AB

Log to File.
No file name configured.

Registers

With this functionality it is possible to read out direct Hiperface DSL Master IP-Core registers.

DSL Master Register Channel 1 Register from the "Drive Interface"

DSL Remote Register "Long Message Data" or "Error Messages" from the encoder (via a short message)

Registers

DSL Master Register Channel 1

0x00 - SYS_CTRL

Set Master Register

Read Master Register

DSL Remote Register

0x20 - PC_BUFFER0

Set Remote Register

Read Remote Register

DSL Master Register Channel 2

0x0f - ENC2_ID

Set Master Register

Read Master Register

Memo Dump

With "Log to File" you can generate a backup of the encoder. (This backup can only internal be used)

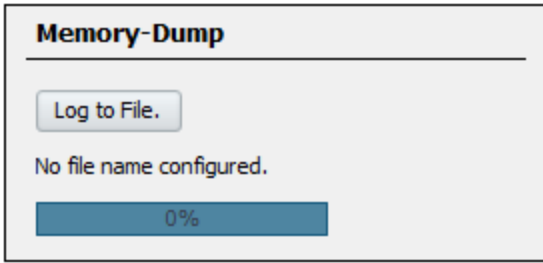

The Hiperface DSL Emulator Mode (Slave Mode)

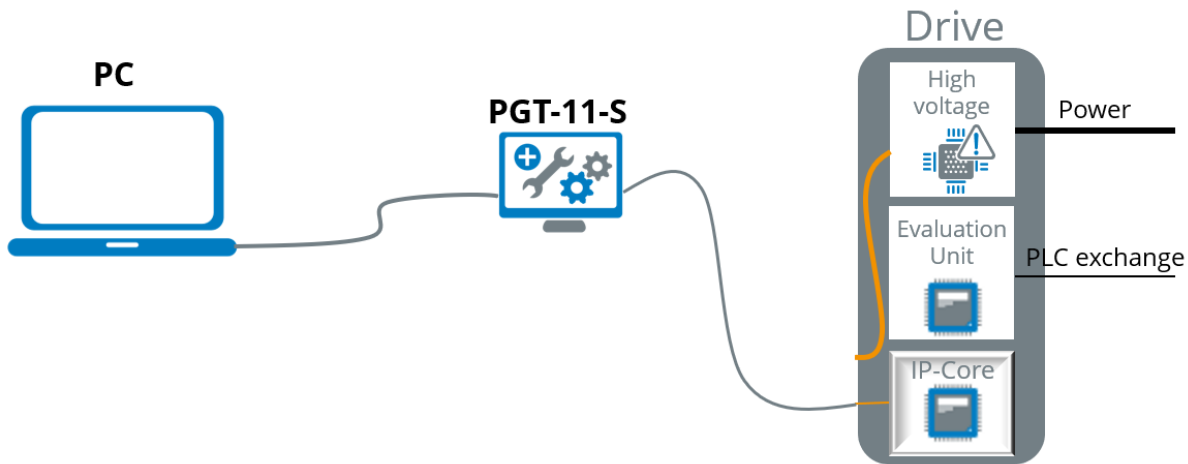

What is the sense of it?

In the Hiperface DSL Emulator Mode, the PGT-11-S is emulating an encoder. But this doesn't mean, you can connect a PGT-11-S to a drive, instead of an encoder this will not work.

The main reason for this mode is, to emulate error messages during developing and testing a drive.

The Hiperface DSL Emulator mode can emulate the following functions:

- DSL Connection (moving position information)
- Error Handling (simulate Hiperface DSL error messages)

If you need the Hiperface DSL Slave Mode / Emulator Mode, we suggest to use the [PGT-13-S Emulator Mode](#) which is much more better and has much more functionality.

The Hiperface DSL Analyzer Mode

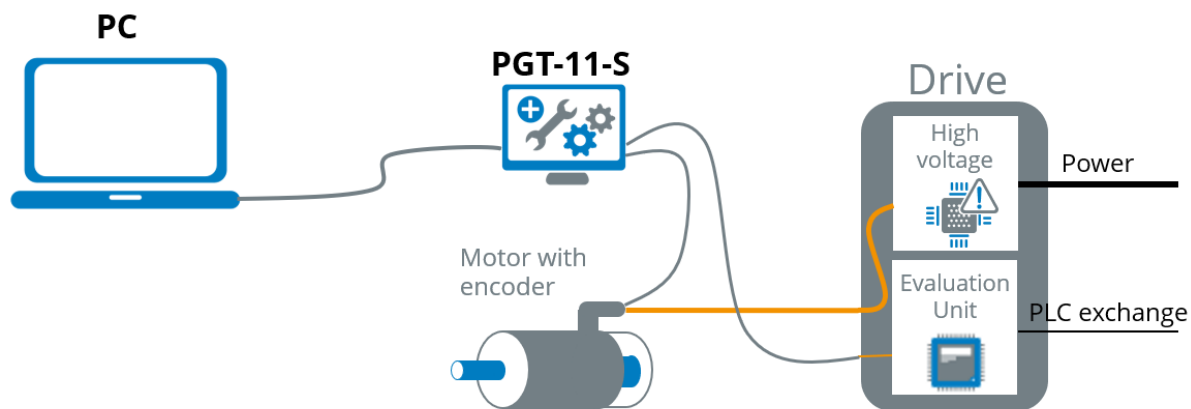

What is the sense of it?

With the analyzer mode, it is possible to capture the Hiperface DSL signal between the encoder and the drive (IP-core). There are 2 different ways to analyze.

This analysis makes only sense for SICK internal people

The Hiperface Host Mode (Master Mode)

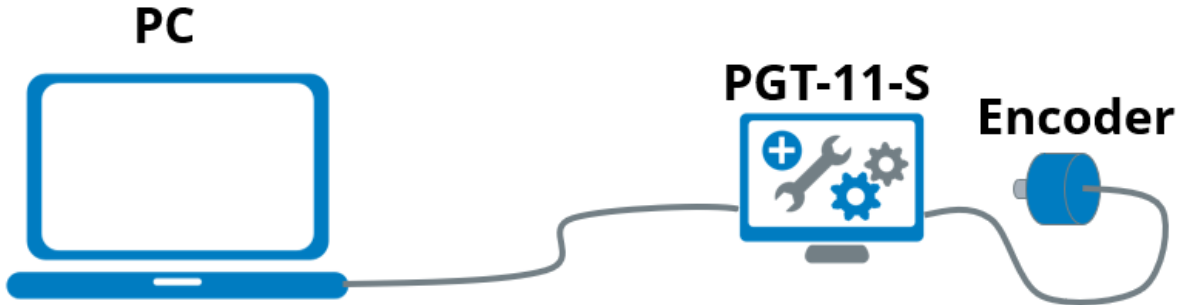

https://video.sick.com/media/t/0_1gds5py5

How to start the Hiperface Master Mode?

1. Choose the Interface Hiperface
2. Select the Hiperface Master Mode

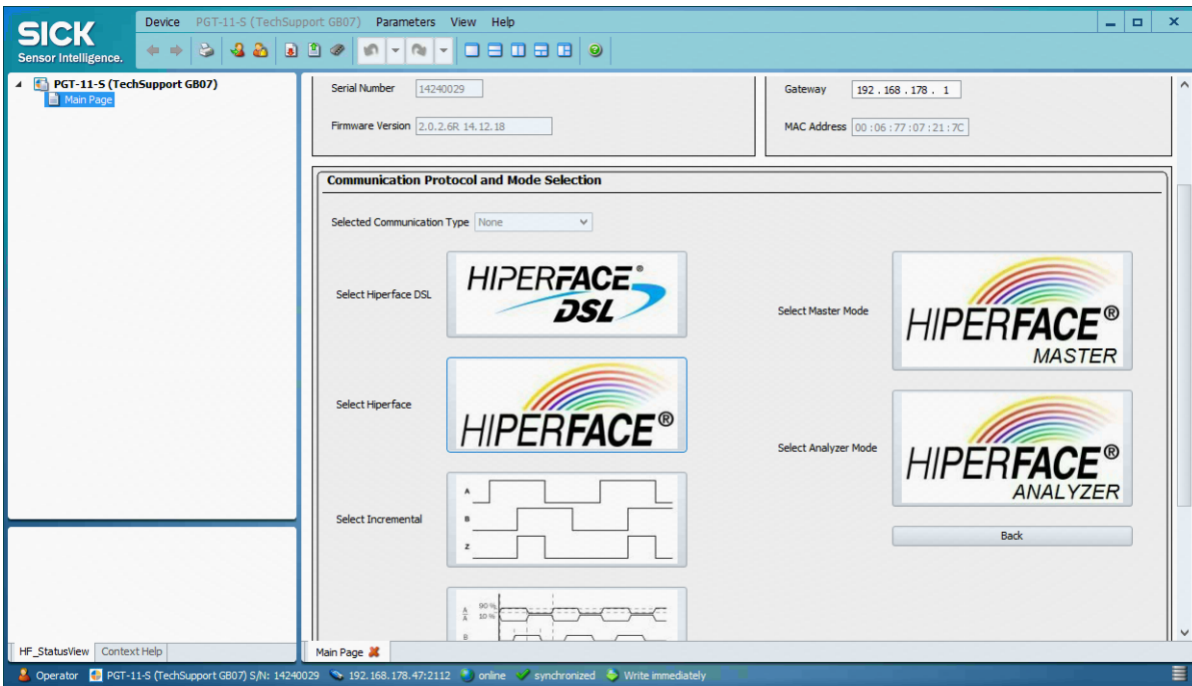

Datasheet

The Data sheet shows the basic data of the connected encoder, which can be read out via the RS485 interface.

- **Encoder Type** information from the Hiperface command "52h" / Byte 1
- **Firmware Revision; Firmware Date; Encoder Serial Number** information from the Hiperface command "56h"
- **Temperature** information from the Hiperface command "44h" / Channel "48h" Temperature in °C and HEX
- **Hiperface Address** the Command Address for the encoder (default 40h)
- **Size of the EEPROM** information from the Hiperface command "52h" / Byte 2
- **Size of free memory; Number of Data Fields** information from the Hiperface command "4Eh"

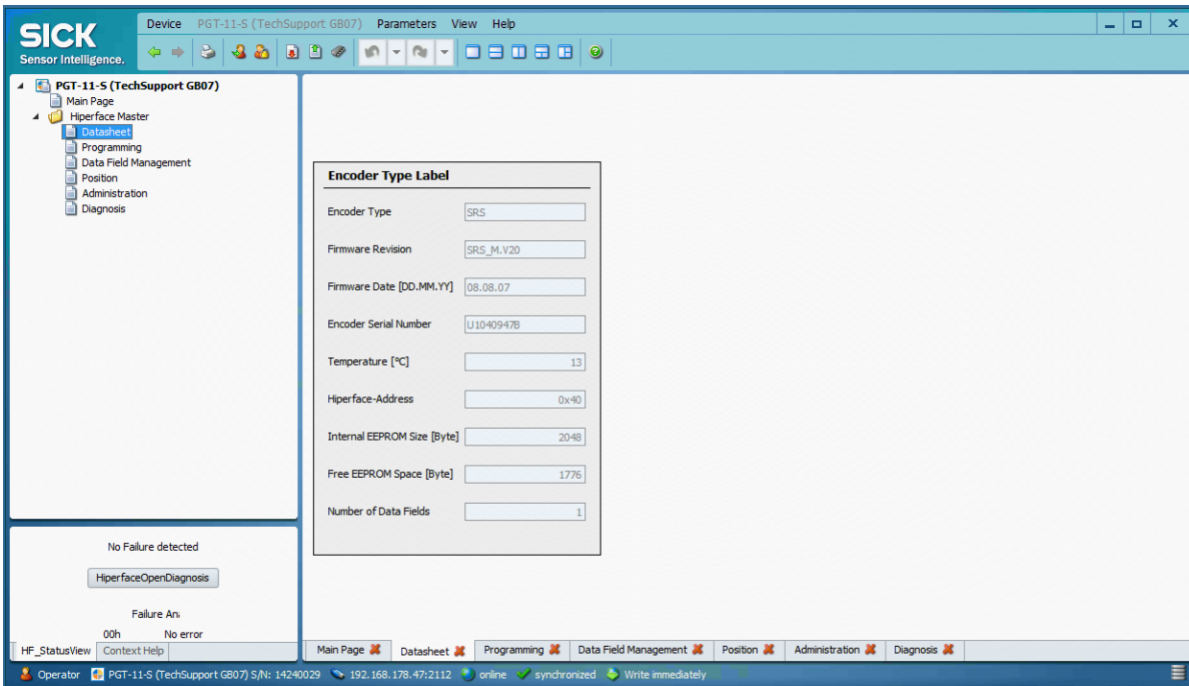

Programming

In the "Programming" there are several basic adjustments possible:

- **RS485-Options** information from the Hiperface command "52h" / Byte 0
To change these settings, please use the Hiperface Terminal with the command "57h" (see the Hiperface description)
- **Hiperface Terminal** here it is possible to execute raw Hiperface commands (it is not necessary to calculate the CS for the command The CS is calculated by the Terminal)
- **Counter Manipulation** Here you can do the Counter settings (We do not know any customer who is using this, but it is existing)
- **Change Encoder Address** Here it is possible to change the encoder's address, which is default "40h". A change of the address is usually not necessary.

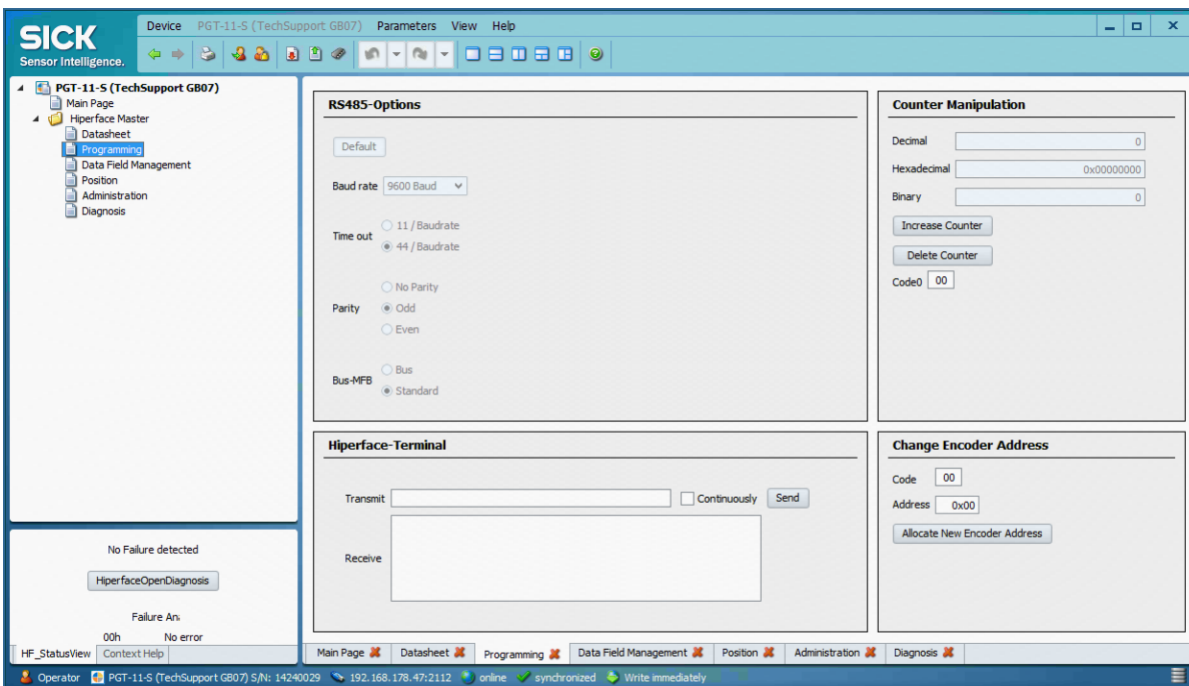

Data Field Management

https://video.sick.com/media/t/0_4irpchen

In the tab "Data Filed Management" it is possible to create, read, change and delete data fields.

SICK only provides the functionality of the data fields. But SICK has nothing to do with the content of the data fields. The content is defined by the drive manufacturer or motor manufacturer.

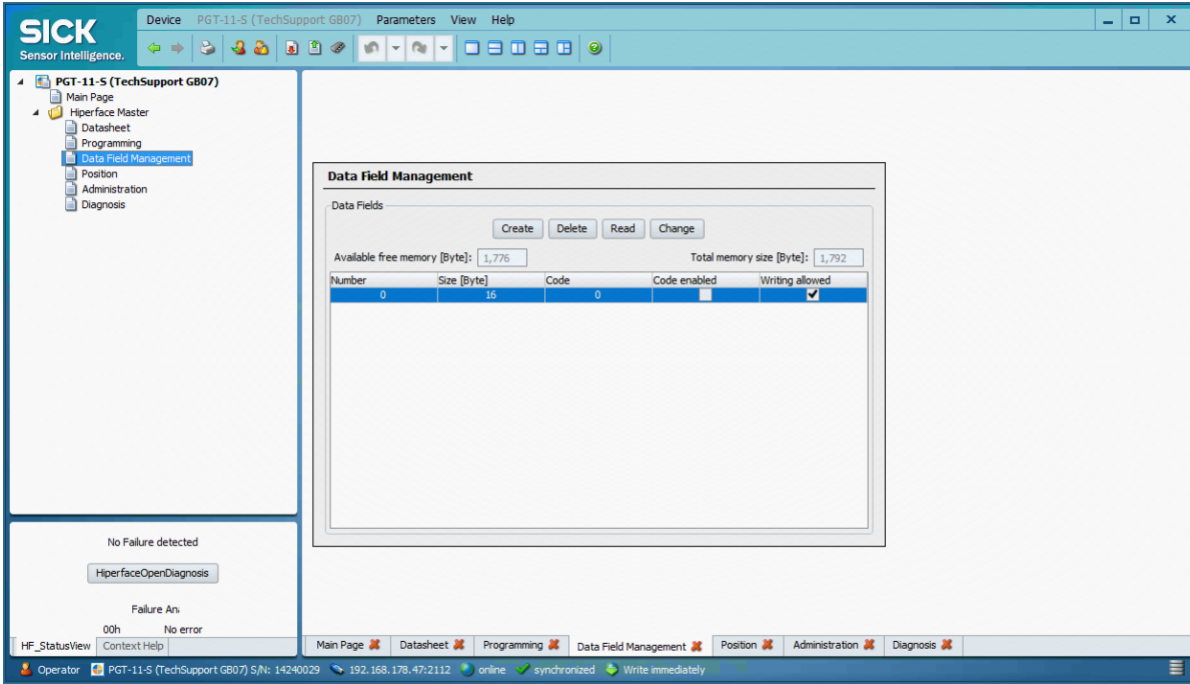

Create Datafield

With the "Create" button, you can open a pop-up window, to adjust the settings of the new data field, you want to create.

The name of the data field is the number of the data field. If it is the 1st one, then it is "data field 0". If it is the 3rd one, then it is "data field 2".

Following attributes can be adjusted:

- **Code:**
The Hiperface encoder supports 4 access codes (code 0 .. 3). Each access code has a length of one byte (00h .. FFh). Each access code can be adjusted as the customer want.
The default value of all 4 access codes is "55h". (The most customers don't change this)
- **Size:**
It is necessary to define the size of the data field. It is only possible to change the size of the last data field.
The adjustable sizes are: 16, 32, 48, 64, 80, 96, 112, 128 bytes
- **Code:** ("active" or "inactive")
This defines, if the access code is needed, to write or to read the data field.
For creating and reading, the access code is "always needed".
- **Write Access:**
With his setting, you define, if it is possible to edit the data field.
(After creating the data field, it makes sense, to enable the write access, to write come content into the data field)
- **Input in:** (ASCII / HEX)
Here you define, how you bring the input to the data field.
- **Data:**
Write here the content.
It is also possible to load some content from the PC into the data field (Important: it is only the content of the data field. The attributes of the data field are not part of the content)

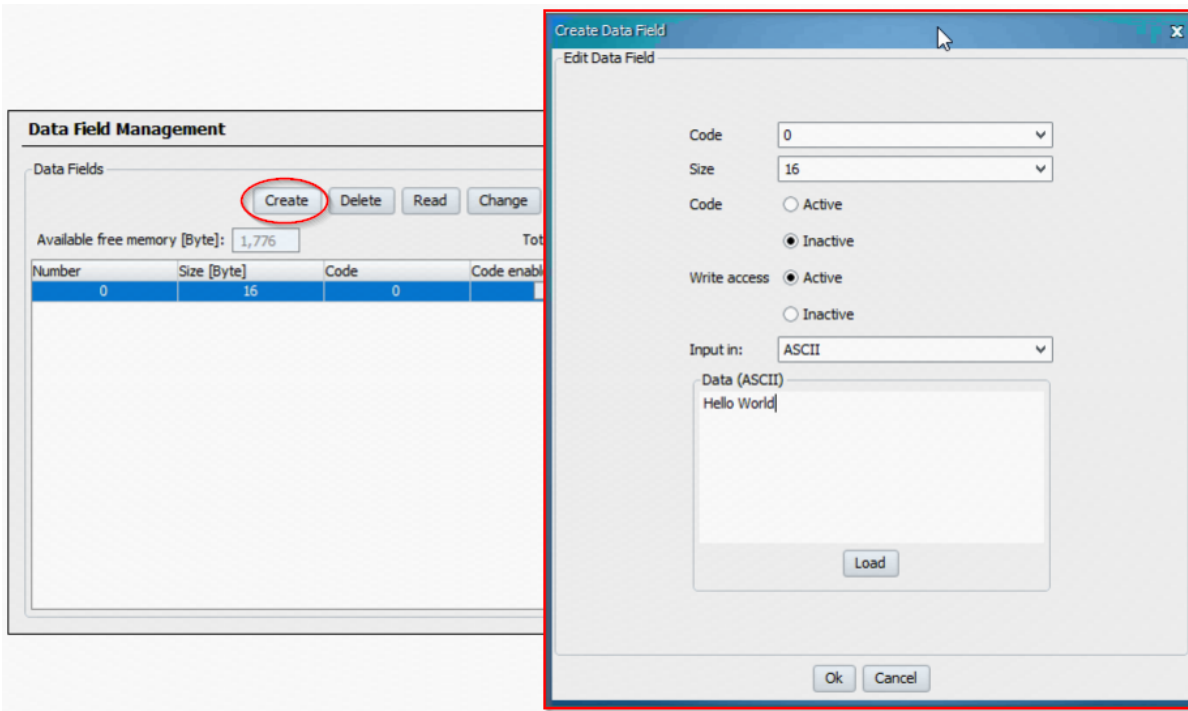

Adjust the data field as needed and fill in the content. Then press "OK". Now you have to type into the additional pop-up window the needed access code, which is default always "55h"

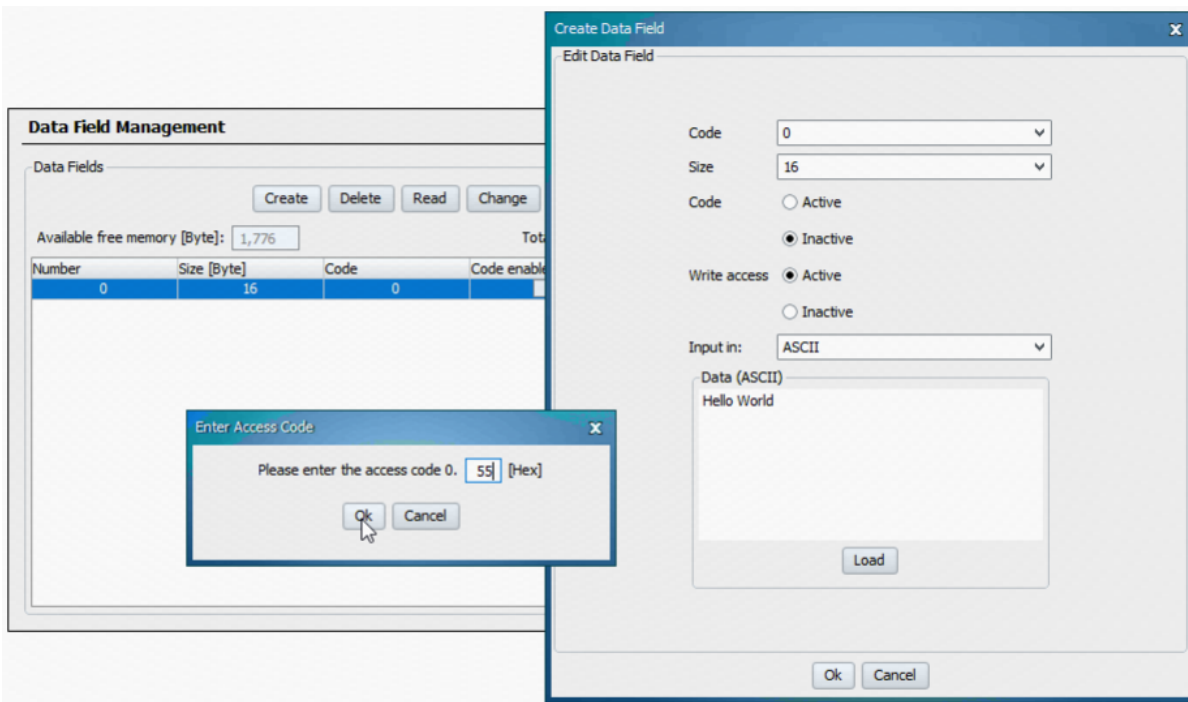

Read Datafield

With the "Read" button, you can open a pop-up window, to read the content of the selected data field.

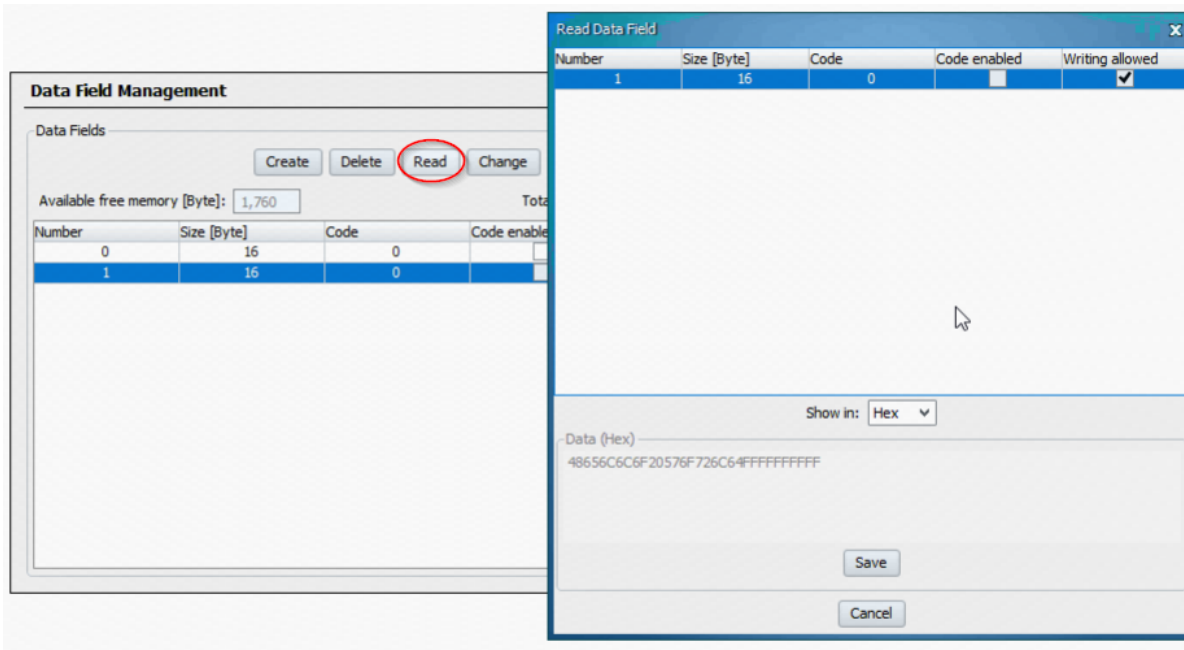

In the window, you have the possibility to adjust, if you want to read the content in ASCII or HEX.

With the "SAVE" button, you can store the content (only the content) of the data field on the PC.

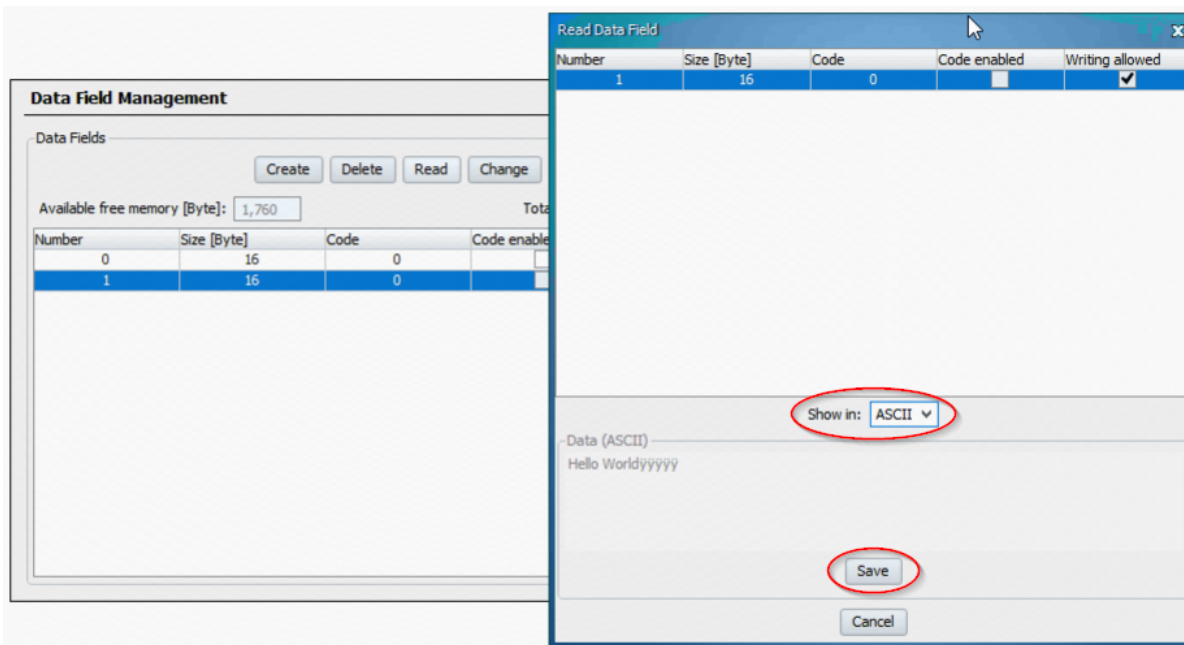

Change Datafield

With the "Change" button, you can open the same pop-up window as at the "Create functionality. The difference is, that the window is already filled with the settings and the content of the selected data field. Now you have the possibility the change settings or to change the content of the data field.

Important: The size of the data field can only be changed, if it is the last data field in the row.

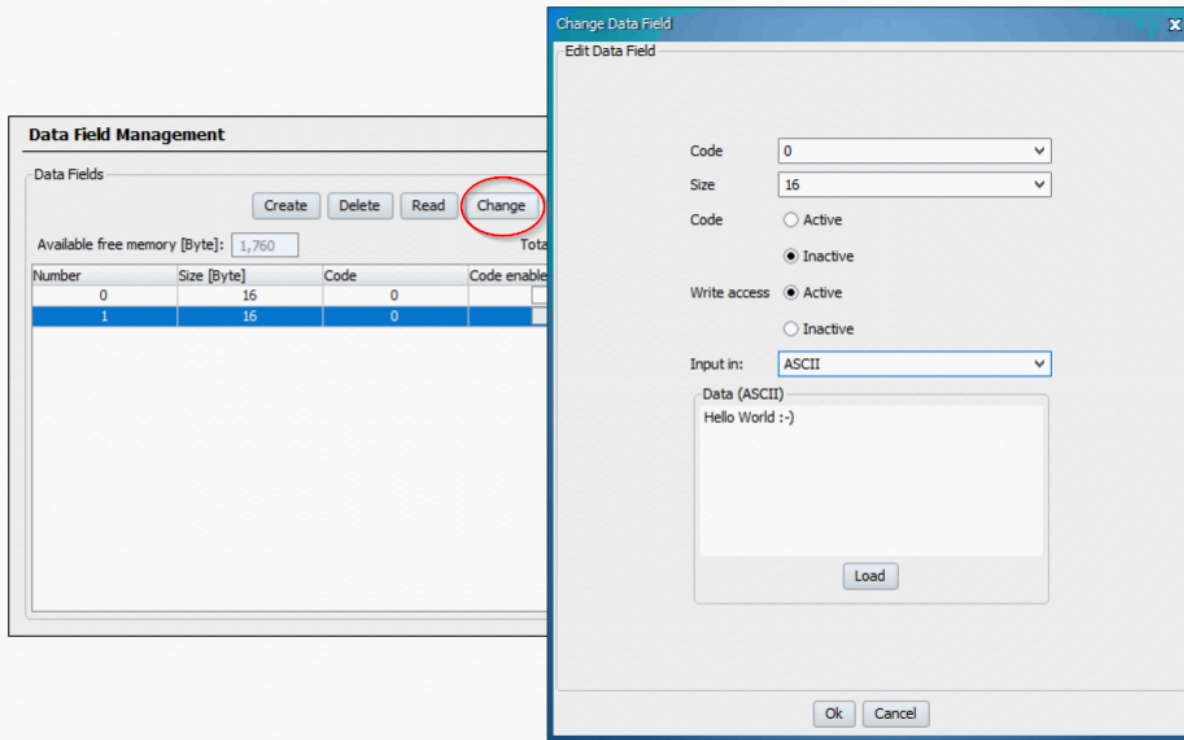

Also here you can select between the ASCII view or the HEX view.

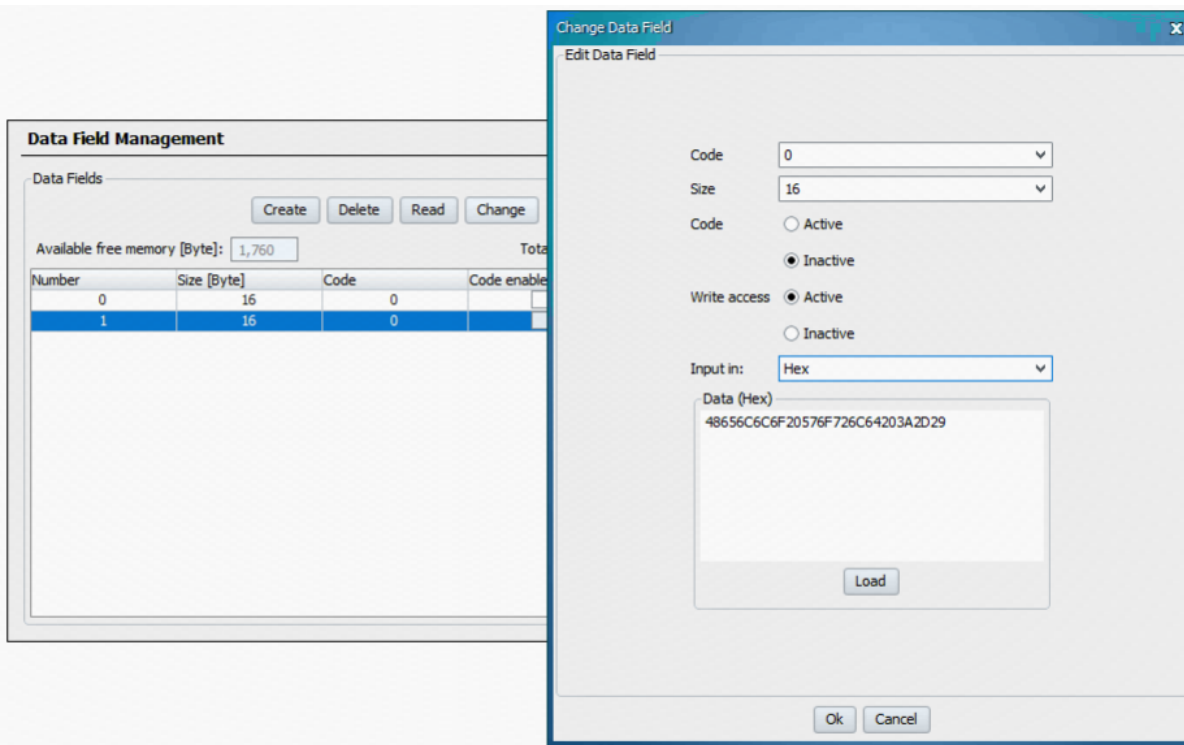

Delete Datafield

With the "Delete" button, you can open a pop-up window, where you can confirm that you want to delete the selected data field.

Important: It is only possible to delete the last data field in a row. It is not possible to delete another data field.

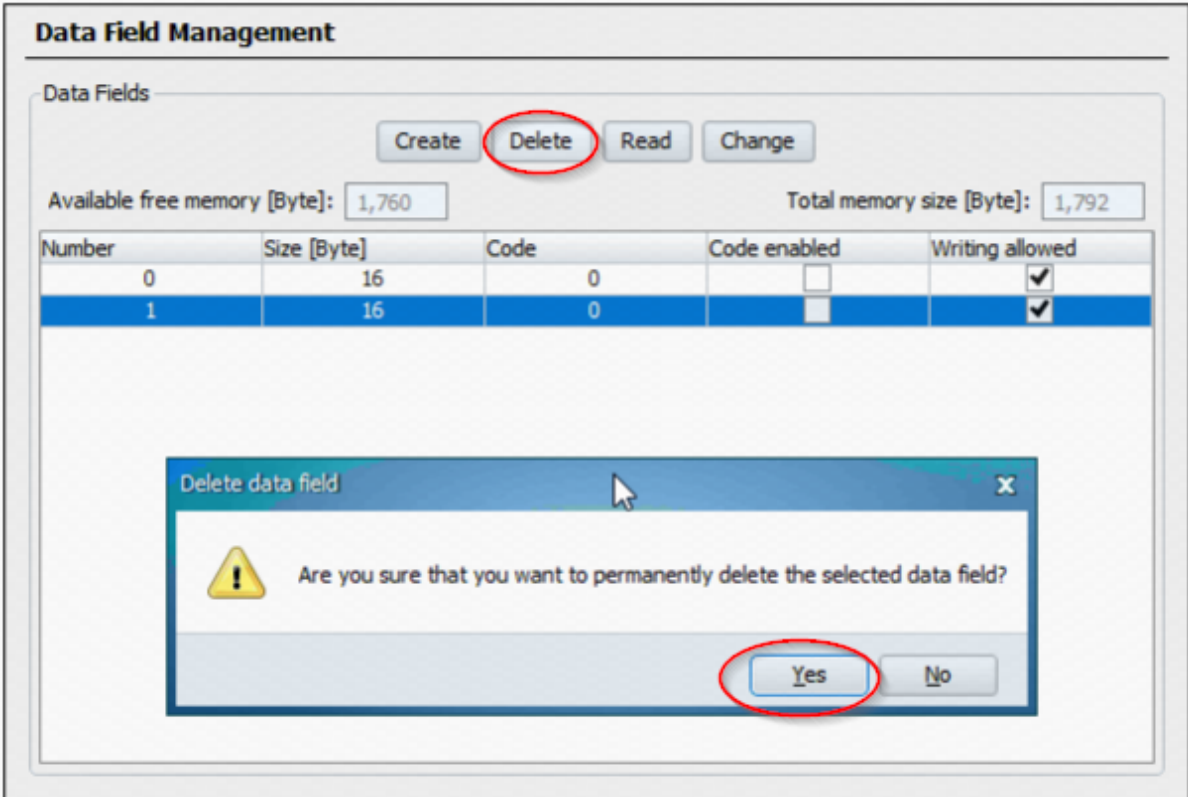

If you have confirmed, that you want to delete the data field, then you have to type into the additional pop up window the needed access code, which is default always "55h"

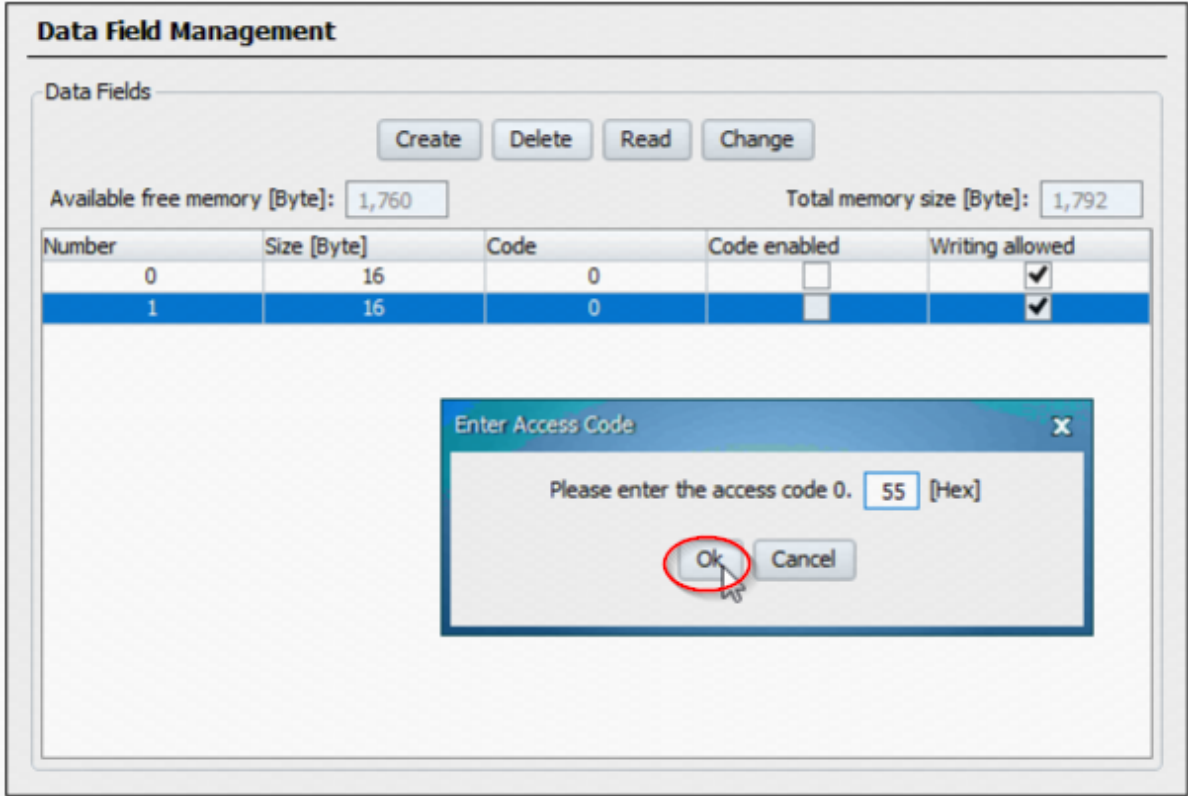

Position

Here you find all about the "Position" information of the encoder

- **Position**

You get the position in a DEC, HEX and BIN value. This is the direct value, which is read out with the command "42h".

It is also possible to log the position information to a file.

The update time of the position information is "1 sec"

- **Set Position**

With this functionality, the encoder's position can be set to the adjusted value, which is written in the field "Position". For the "Set Position", there is the Code0 needed, which is default "55h".

There are basically 2 ways to do this:

- 1. without synchronization (tick in the checkbox)
After the button "Set Position" is hit, the current position value is set to the adjusted value in the field "Position". The synchronization between the absolute position and the SIN/COS will be lost.
- 2. with synchronization (no tick in the checkbox)
After the button "Set Position" is hit, the current position value is set to the adjusted value in the field "Position", but without changing the last 5 bits. This means, the adjusted set position and performed set position will be not the same. There will be a maximum difference of 31 steps. Depending on the resolution of the encoder, this can be more or less ° or mm.

- **Set Synchronisation of absolute position and analog SIN/COS**

When the functionality "Set Position" is used, the encoder calculates an offset between the physical position and the output position.

With the functionality "Set Synchronization" this offset is written back to "0" (the default value).

What is the meaning of "Synchronization between the absolute position and the analog SIN/COS"?



When the encoder leaves the production, there is a defined alignment between the SIN/COS signal and the absolute position.

The absolute position starts at the beginning of a SIN/COS period (SIN = 0, COS = 1).

After a "Set Position" this alignment can be shifted. The reason for this is, that it is physically not possible to shift the SIN/COS value, because the SIN/COS value is taken directly from the code disc (no calculation or emulation).

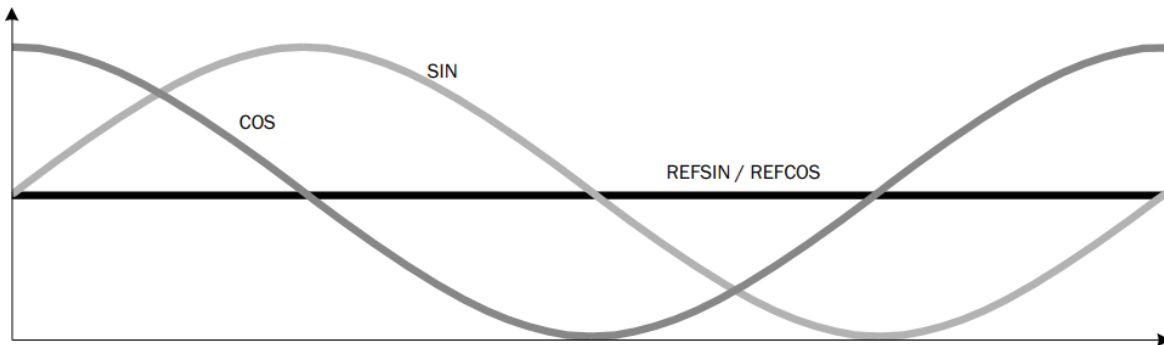

0	1	2	3	4	5	6	7	8	9	10	11	12	13	14	15	16	17	18	19	20	21	22	23	24	25	26	27	28	29	30	31
---	---	---	---	---	---	---	---	---	---	----	----	----	----	----	----	----	----	----	----	----	----	----	----	----	----	----	----	----	----	----	----

Default alignment of absolute position (5 LSBs) to one Sin/Cos period

27	28	29	30	31	0	1	2	3	4	5	6	7	8	9	10	11	12	13	14	15	16	17	18	19	20	21	22	23	24	25	26
----	----	----	----	----	---	---	---	---	---	---	---	---	---	---	----	----	----	----	----	----	----	----	----	----	----	----	----	----	----	----	----

Example for shifted alignment of absolute position to Sin/Cos period

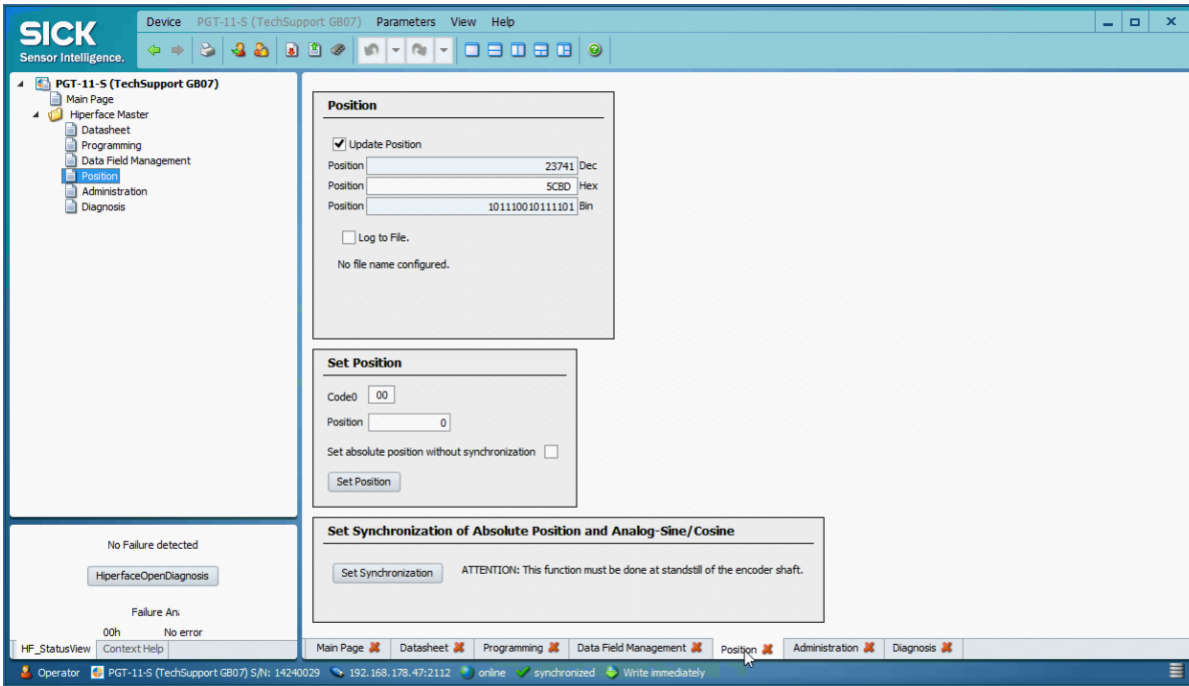

Administration

In the tab "Administration" it is possible to change the 4 access codes (Code0 .. 3). The default setting is for all 4 codes "55h". It is possible to adjust a value between 00h .. FFh.

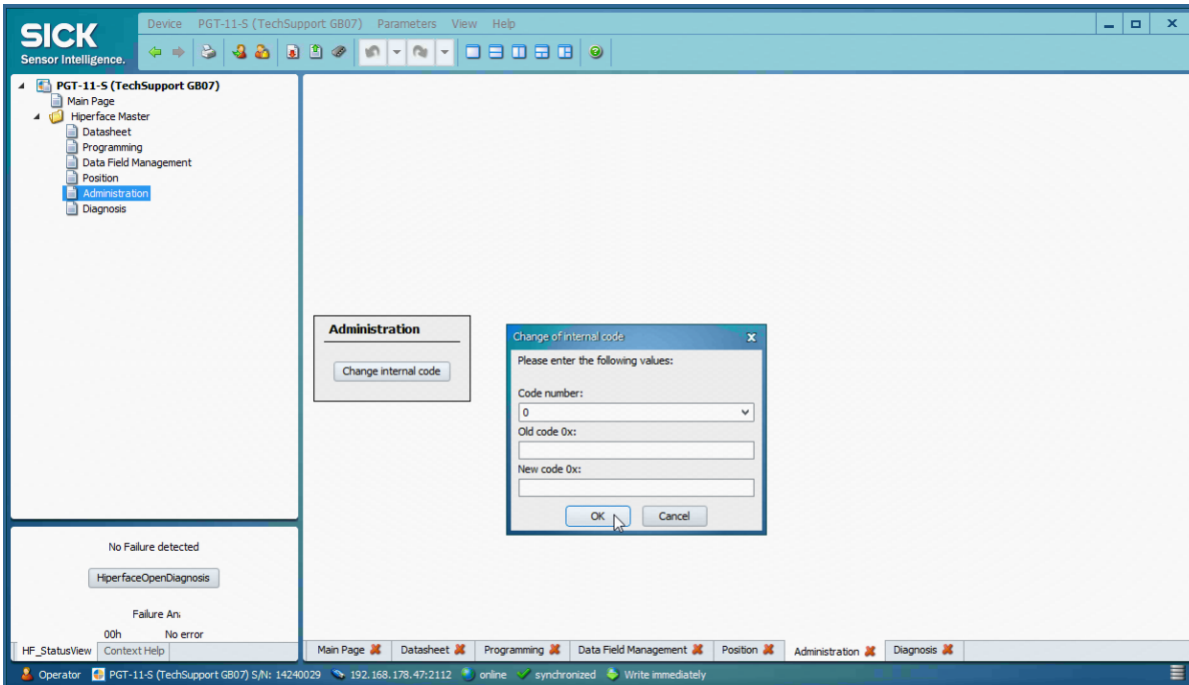

Diagnosis

The tab "Diagnosis" shows the error log of the Hiperface encoder. The Hiperface encoder can store up to 4 errors.

- In the top area, you see possible errors which occurred during the start up at the encoder.
- In the bottom area, you can read out the error log again.

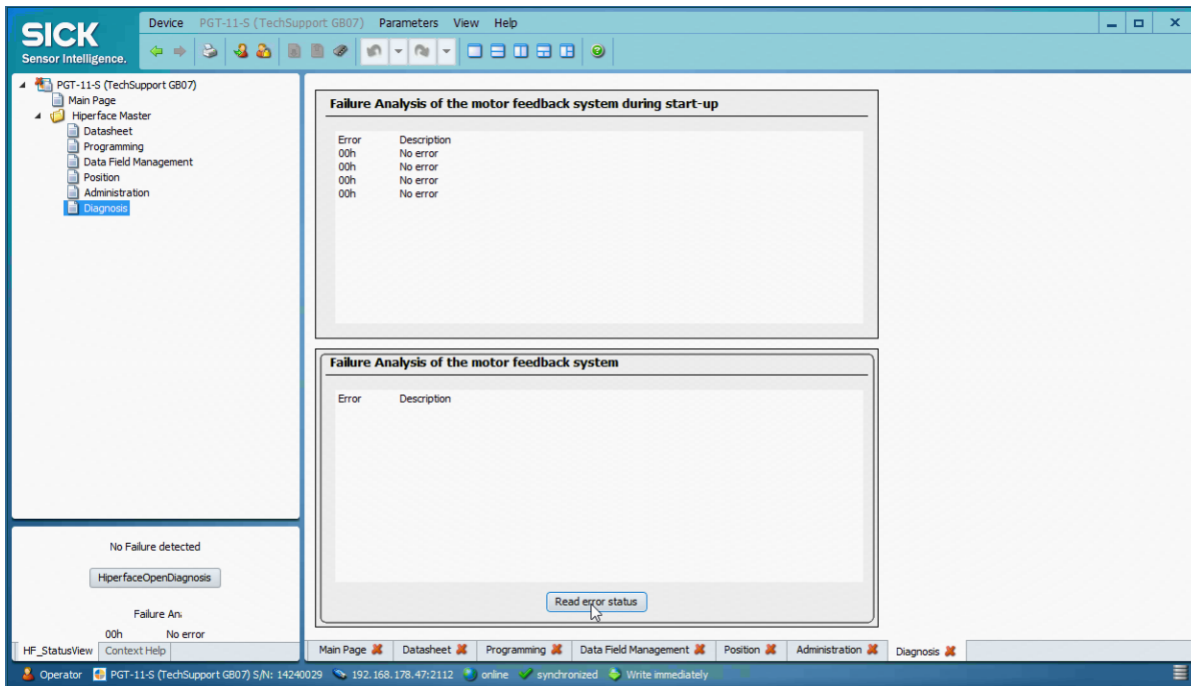

Please keep in mind:



- If an error is read out from the encoder, then it is deleted from the error log.
- If the encoder is switched off, the error log is deleted, because the errors are only stored in the RAM of the encoder.
- There are also many errors, which are reported directly (20h, 21h, ...). They will be never visible in the error log.

The Hiperface Analyzer Mode

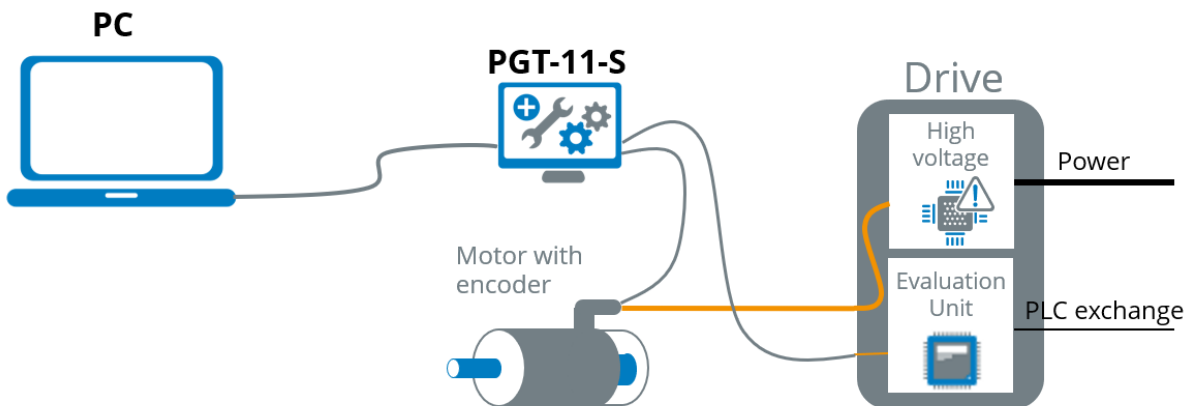

https://video.sick.com/media/t/0_Oppka2p7

How to start the Hiperface Analyzer Mode?

1. Choose the Interface Hiperface
2. Select the Hiperface Analyzer Mode

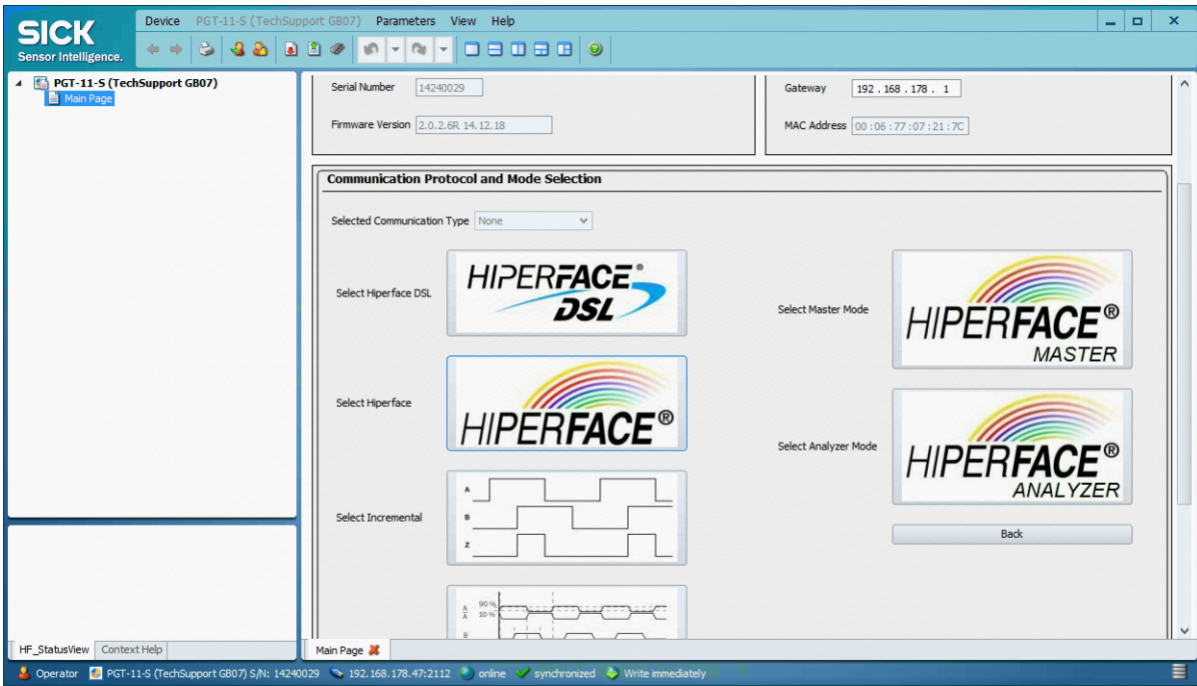

What is the sense of it?

With the analyzer mode, it is possible to capture the Hiperface signal between the encoder and the drive. There are 2 different ways to analyze (in the "Trigger Options").

- Oscilloscope
- Hiperface Tap

In the "Trigger Options, you can choose, which Mode you want to use:

The Oscilloscope Mode

In the "Oscilloscope Mode" you can check the Quality of the SIN/COS signals.

There is the possibility of a "Single Shot" mode or a "Continuous Measurement" mode.

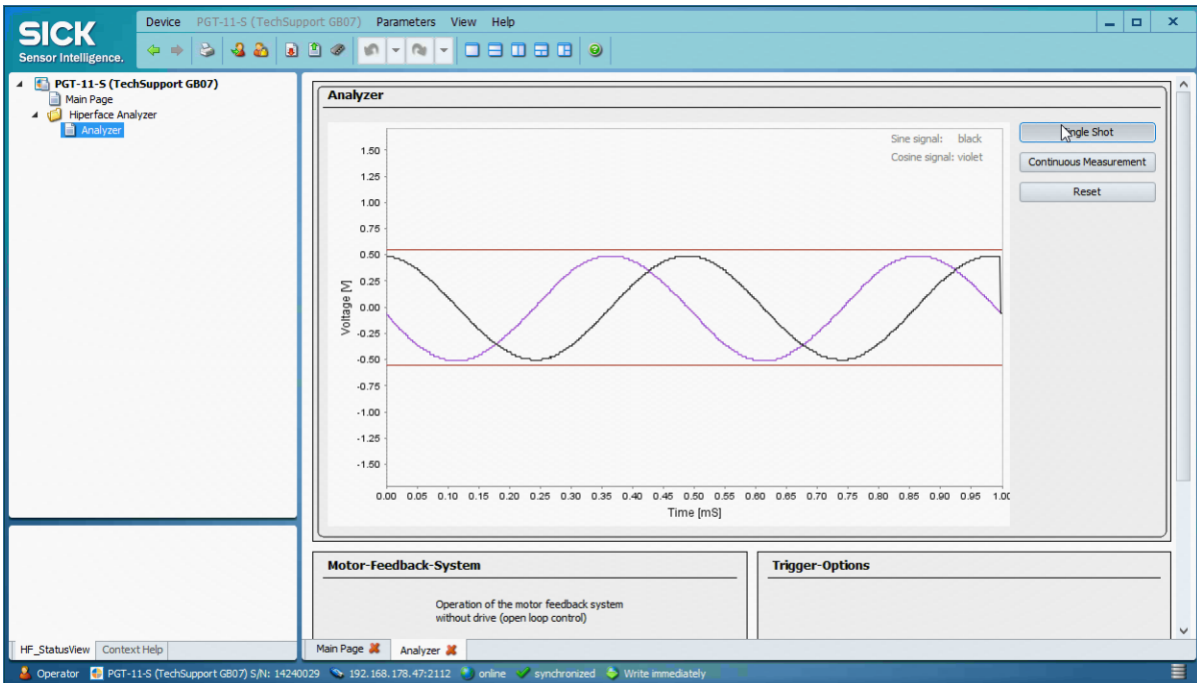

The Oscilloscope mode can be used in 2 different settings:

1. Put the PGT-11-S between an encoder and a drive for this mode it is important, that the power supply for the encoder is switched off (this is the default mode)
2. Connect only an encoder to the PGT-11-S (compared to the Master Mode) for this mode it is necessary to switch on the power supply of the encoder.

How to switch on the power supply?

Click on "Select operation mode", which you see in the picture below and confirm with "yes".

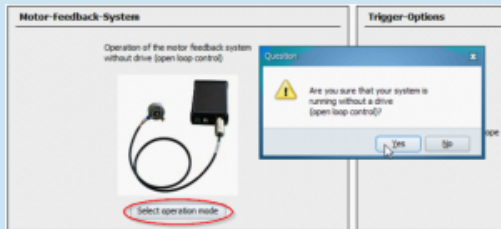

Then you can capture the SIN/COS signals

For a more precise test of the SIN/COS signals, we recommend to use a real oscilloscope, because a scope is much more precise and you can analyze more.

The Hiperface Tap

In the Hiperface Tap mode, it is possible to capture the RS485 communication between a drive and an encoder.

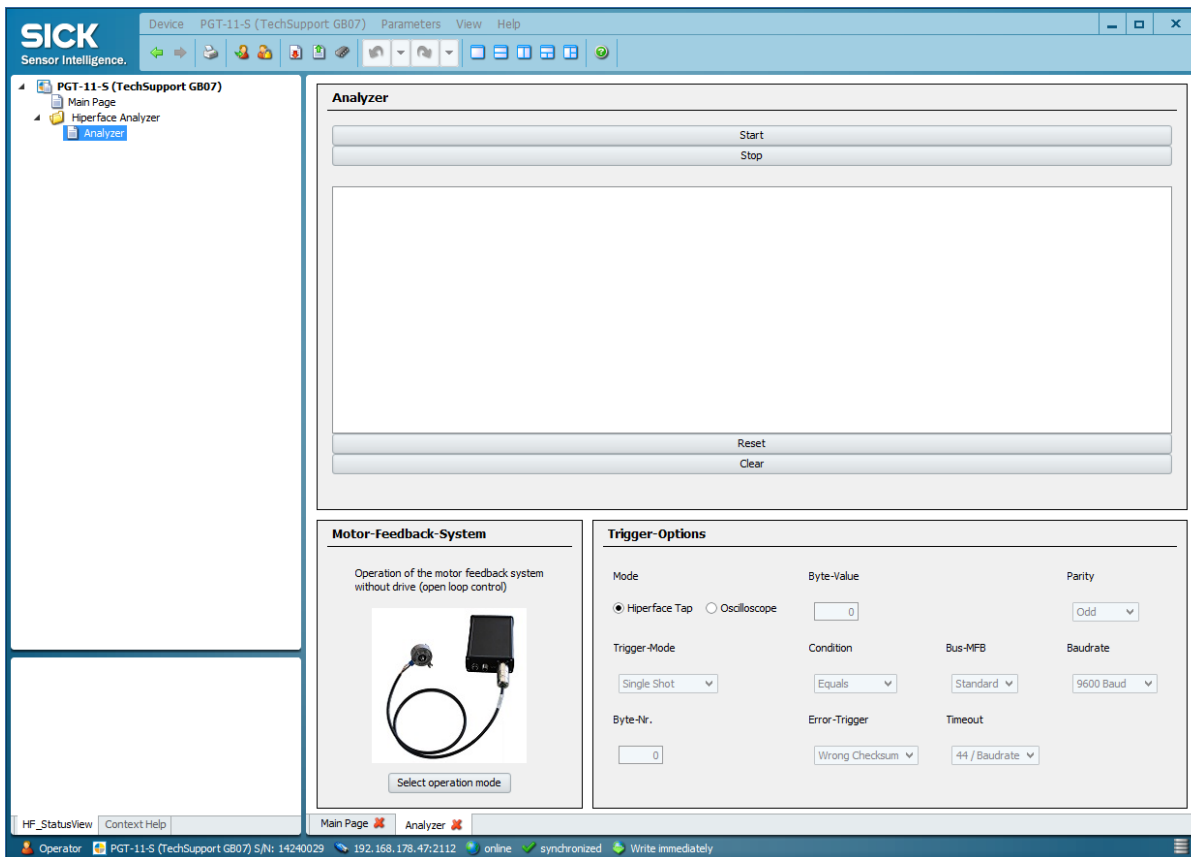

This functionality basically works, but is not much user friendly.

If we want to capture the Hiperface RS485 communication, than we are using a Scope with RS485 UART decoding or another digital decoding tool.

Incremental Encoders (only VFS60)

SICK suggest to use the following tools:

[PGT-08-S](#)

[PGT-10-S](#)

[PGT-10-Pro](#)

Incremental with Commutation (only the CKS36-PFBPROGR)

This part of the PGT-11-S is to program the programmable version of the [CKS36](#). This device is sold in very low quantities.

If you have questions to the programming, don't hesitate to contact us.

FAQ

How can I update the PGT-11-S Firmware?

Please check if you have the latest firmware on your PGT-11-S. The latest firmware is the 2.0.2.6R.

How is a firmware update done?



1. You need the the installed SDD-file version, in SOPAS, of the current firmware of the PGT-11-S
2. You need the change the "additional timeout" in the Ethernet settings (see the user manual of the firmware update)
3. You need to install the SDD-file version, in SOPAS, which you want the PGT-11-S update to
4. Now you can update the PGT-11-S see the user manual of the firmware update





In the below table you find the needed files

- SDD: Sopas device description is needed that SOPAS recognize the PGT-11-S in the software
- SSP: update file for the PGT-11-S
- User manual: detailed description of the update process

There were 3 firmware versions for customers released.

If you have another firmware version, please contact us, if you need help.

	V1.11	V1.20	V2.0.2.6R
user manual	1. firmware	 2015-03-2...PGT11.pdf	 2018_08_0...v1.00.pdf
SDD-file sopas device description			

			
SSP-file PGT-11-S update file	1. firmware		

[DSP-Link](#)

(Stefan Gail, 05.06.2020)

Problems with the Set Position at a EKS36 / EKM36, in combination with the PGT-11-S, with STM32 controller

Problems with the Set Position at a EKS36 / EKM36, in combination with the PGT-11-S, with STM32 controller

Basic Problem

EKS36 / EKM36 with a date code "jjww xxxx" and later are using a new μ -controller. We changed from the ST08 to the STM32. With this μ -controller change, we also had to write a new firmware for this encoder.

Due to security law, we had to change the password management of the encoder. The passwords 0 .. 4 are unchanged this means, no change for the customer.

access level	password
0	(0000) default
1	1111
2	2222
3	3333
4	4444

But there is a change in the higher password levels (5 .. 7).

What is the Problem with the PGT-11-S?

At the start up, the PGT-11-S tries to enter the access level "7" in the encoder. This is basically working at all current Hiperface DSL encoders.

But at the new EKS36 / ELM36 with STM32 controller (starting from date code "jjww xxxx" and later) there is a difference. The PGT-11-S can not enter the access level "7". And it stays in the access level "0".

The main problem is, that the "Set Position" is no more working, because this command requires the access level "4".

How to solve the problem?

The user has to enter the access level "4" in the encoder manually.

The following video describes, how this is done.

The [link for the video](#), to send to the customer:

https://video.sick.com/media/t/0_1jjzako9

Here a Makro, which you can directly load into the PGT-11-S, to enter the access level "4".

(Stefan Gail, 28.03.2024)

Is it possible to communicate directly with the PGT-11-S API (without SOPAS)?

It is possible to communicate directly with the PGT-11-S via the API. The customer doesn't need SOPAS. In the file below, all available commands are explained.

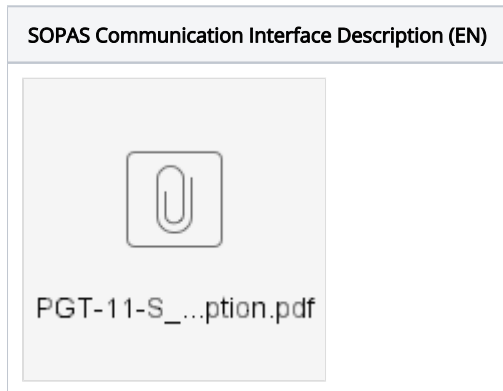

The API communication can only programmed with "java".

In the file below, there are some examples for the customer.



(Stefan Gail, 16.06.2020)

How to enable the Access Level at a EKx36 with STM32 via the API

How to enable the Access Level at a EKx36 with STM32 via the API

!!! internal !!! only for customers which are using the PGT-11-S via the API

Please use this Script, which enables the Access Level:



Wir haben es jetzt so gelöst, dass wir auf PGT-Seite den „dsl_MasterLongMsgTunnel“ nutzen, um auf Geber-Seite über die RID 112h die internen Access Level freizuschalten.

Damit kann das PGT-11 weiterhin im Access Level 7 arbeiten.
Zum Schluss der Session werden über den gleichen Zugang die internen Access Level wieder deaktiviert.

Mit diesem Workaround sind keine Anpassungen am PGT-11 notwendig, wir nutzen die generischen Zugänge die es Stand heute schon zur Verfügung stellt.

(Stefan Gail, 16.11.2023)

How does the wiring of the DSL cable DSL-1202-G01MA (2061361) look like?

If you want to build the cable DSL-1202-G01MA (2061361) by yourself, it does not work if you only wire DSL+ and DSL-.

It is necessary to make a bridge between DLS+ and Power + and another bridge between DSL- and Power-.

Stecker HIPERFACE DSL® OUT		
PIN	Signal	Erklärung
1	DSL+	HIPERFACE DSL®-Daten
2	DSL-	HIPERFACE DSL®-Daten
3	PWR-	Masseanschluss
4	PWR+	12 VDC Versorgungsspannung



1	brown	DSL+
2	white	DSL-
3	blue	Power-
4	black	Power+

The wiring should look like this:

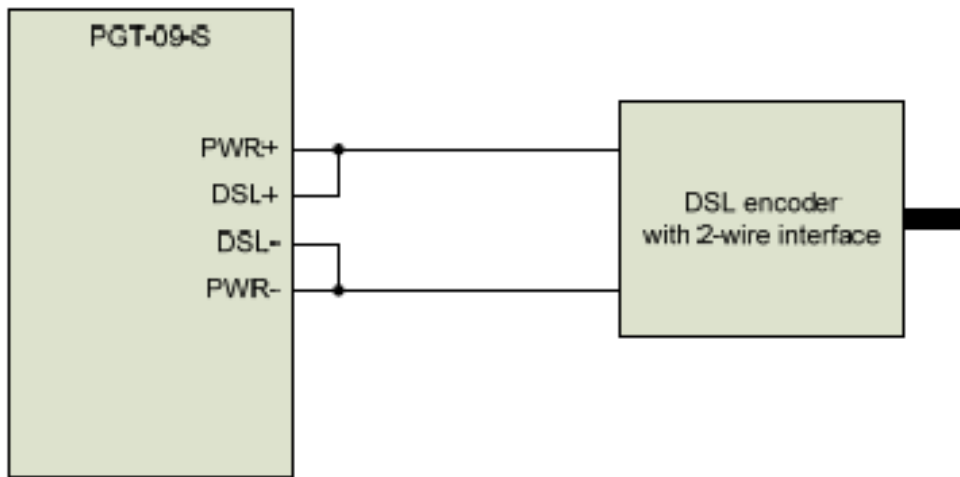

pin M12	color M12	function	color JST	pin JST
1/4	brown/black	DSL+	gray	2
2/3	white/blue	DSL-	green	3

[DSP-Link](#)

(Stefan Gail, 01.02.2023)

Are there any tutorial videos for the PGT-11-S available?

On [SICK.com](#) you find on the landing page of the [PGT-11-S](#), 2 tutorial videos see the picture:

Accessories

Further accessories



Type: PGT-11-S LAN | Part number: 1057324 | Usual availability: ●

[Log in to get your price](#)

1

[ADD TO CART](#)

[Request quote](#)

[PDF](#) [Product data sheet](#)

[Copy shortlink](#) | [Add to wish list](#)

- [Technical details](#)
- [Downloads](#)
- [Accessories](#)
- [Videos](#)**
- [Customs data](#)



Tutorial sVIP® - PGT-11-S | SICK AG



Tutorial sVIP® – PGT-11-S in HIPERFACE DSL Mode | SICK AG

Here the direct links to the videos:

[Hiperface](#)

[Hiperface DSL](#)

[DSP-Link](#)

(Stefan Gail, 23.01.2020)

Where is my SET-Position button?

Maybe you are using the PGT-11-S with the 1st firmware version "1.11". At this version, we missed the SET-Position button in the Hiperface DSL Master Mode.

We suggest to update the PGT-11-S to the latest firmware version (see another FAQ).

You can also do the SET-Position manually see the attached document:



PGT-11-S_Set-Position_1.00x.PDF

[DSP-Link](#)

(Stefan Gail, 20.01.2022)

Do we have a PGT-11-S user manual of the firmware version 1.20?



2017-07-12 PGT-...7M_TS 1.02x.pdf

[DSP-Link](#)

(Stefan Gail, 20.01.2022)